

Nikon

AUTO REFRACTOMETER NR-5500

Instructions



NIKON CORPORATION

Tokyo, Japan

AUTO REFRACTOMETER NR-5500

PRECAUTIONS FOR OPERATIONS

Nikon Corporation is not responsible for the safety and reliability of this instrument in the following cases:

- (1) Any person other than a Nikon-authorized sales or service person has assembled, adjusted or repaired this instrument in a way other than described in this manual.
- (2) The instrument was not used in accordance with this manual.

1. Safety Precautions

- 1) Never disassemble this instrument (there are hazardous high- voltage parts inside).
- 2) Make sure that the patient (particularly a child) does not get the fingers caught in gaps on the instrument.

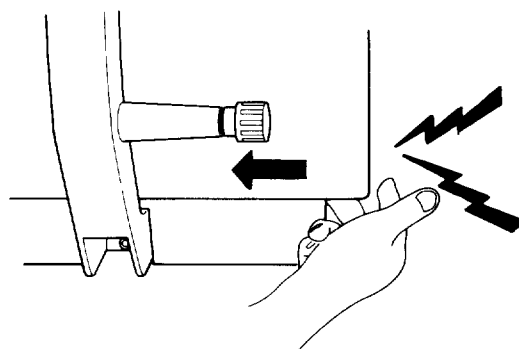

- 3) Make sure to not bump the measuring head against the patient's nose (when moving the measuring head toward the patient or to the right or left).

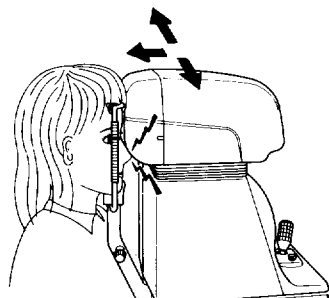

2. Installation

- 1) When carrying the instrument, lift from the base section.

Do not lift by the forehead rest, measuring head or joystick.

Good

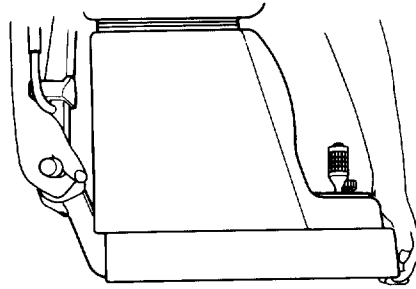

Not good



- 2) The best environment for operation is between approximately 10-30°C or 50-86°F room temperature, and less than 70% humidity.

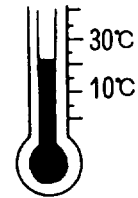

- 3) This instrument is reasonably dust-resistant, but install it away from any source of dust.

Not good

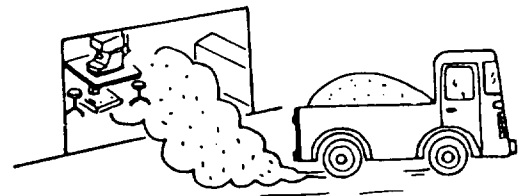

- 4) The best place for installation is a dimly lit room. The patient's side of the instrument should not be subject to bright light.

Not good

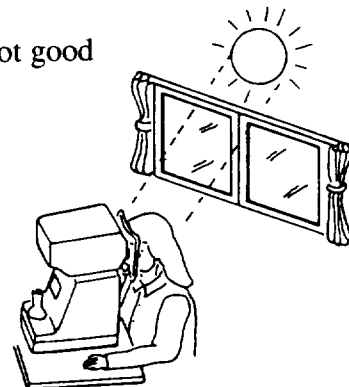

- 5) Whenever you transport the instrument install and tighten the securing screws (see pages 5 and 6).

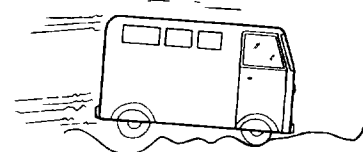

3. Handling Precautions

- 1) Never press the touch panel of the TV monitor with a sharp object such as a ball point pen.
- 2) Handle this instrument with great care; it is a precision optical instrument with many electronic parts.
- 3) Do not open the cover of the main body and the IC card reader/writer cover.

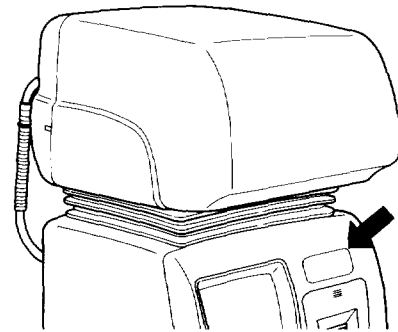
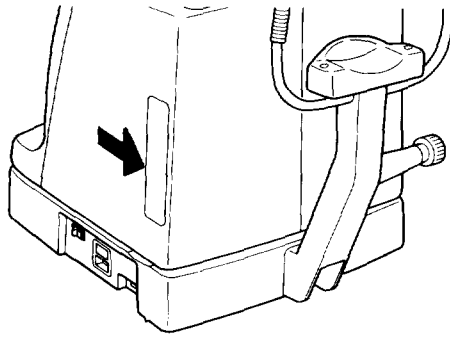

4. Maintenance

- 1) In this precision optical instrument, correct measured values will not be obtainable, if the measuring window glass is smudged with grease from the patient's nose, finger prints or dust. Keep the measuring window glass clean. When you clean the glass, be careful not to scratch or break it (see Section 7-(4) on page 43).
- 2) Before changing the fuse, make sure you turn OFF the power switch and disconnect the power plug from the main outlet (see Section 7-(2) on page 43).
- 3) After operation, turn OFF the power switch and cover the instrument with the vinyl cover provided.

Not good

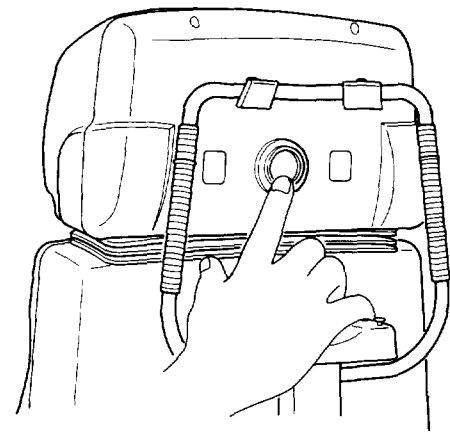

Table of Contents

1. Nomenclature	1
2. Preparation	5
2-1. Removing Screws for Transport	5
2-2. Power ON	7
2-3. Measurement Preparation	7
3. Measurement Method	9
4. Enhanced Retro Illumination Setting	21
5. Touch Panel	23
(1) Measurement Screen	23
(2) Name Entry Screen	25
(3) Menu Screen	27
(3)-1 Memory Data List Screen	28
(3)-2 NO. & CLOCK SET Screen	34
(3)-3 Message Entry Screen	36
(3)-4 SYSTEM DATA SET Screen	37
(3)-5 Automatic Fogging Cancel Screen	38
6. Automatic Power Saving	39
7. Maintenance	41
(1) Replacing a Paper Roll	41
(2) Changing the Fuses	43
(3) Cleaning the Chin and Forehead Rests	43
(4) Cleaning the Measuring Window	43
(5) Cleaning the Touch Panel	44
(6) Model Eye	44
(7) Error Indication	44
8. Connecting with an External Device	45
9. Specifications	47
10. Equipment Supplied	49

1. Nomenclature

MAIN BODY (Operator side)

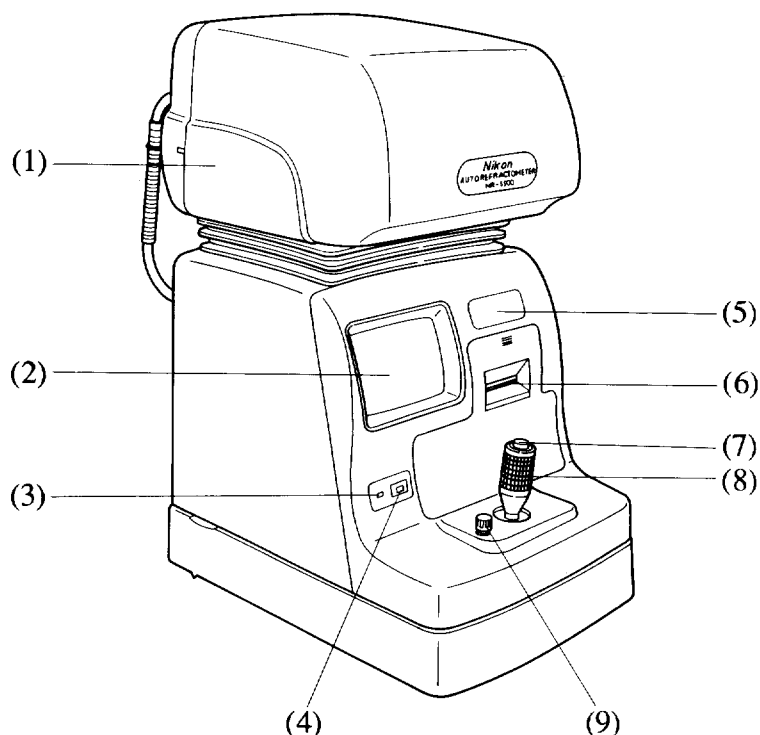

Figure 1-1

- (1) Measuring head..... Incorporates the measuring mechanism.
- (2) TV monitor and touch panel... Enables the operator to take measurements while observing the patient's eye on the TV monitor. Measurement data is also displayed on the monitor. Touch the monitor display lightly with your finger (touch panel operation).
- (3) POWER lamp..... Lights when the power switch is set to ON.
- (4) PRINT switch..... Press this switch to print out data. In the enhanced retro illumination setting mode, the anterior segment LED is turned on and off by setting this switch to ON and OFF, respectively.
- (5) IC card reader/writer mount... The optional IC card reader/writer is mounted here.
- (6) Print paper outlet..... Printouts are discharged from this slot.
- (7) Start button..... Press this button to start measurement.
- (8) Joystick lever..... Is used for right/left or forward/backward positioning during measurement. Turning this lever can move the measuring head up and down.
- (9) Measuring base hold Is used to lock this instrument after right/left or forward/backward positioning is completed.

(Patient side)

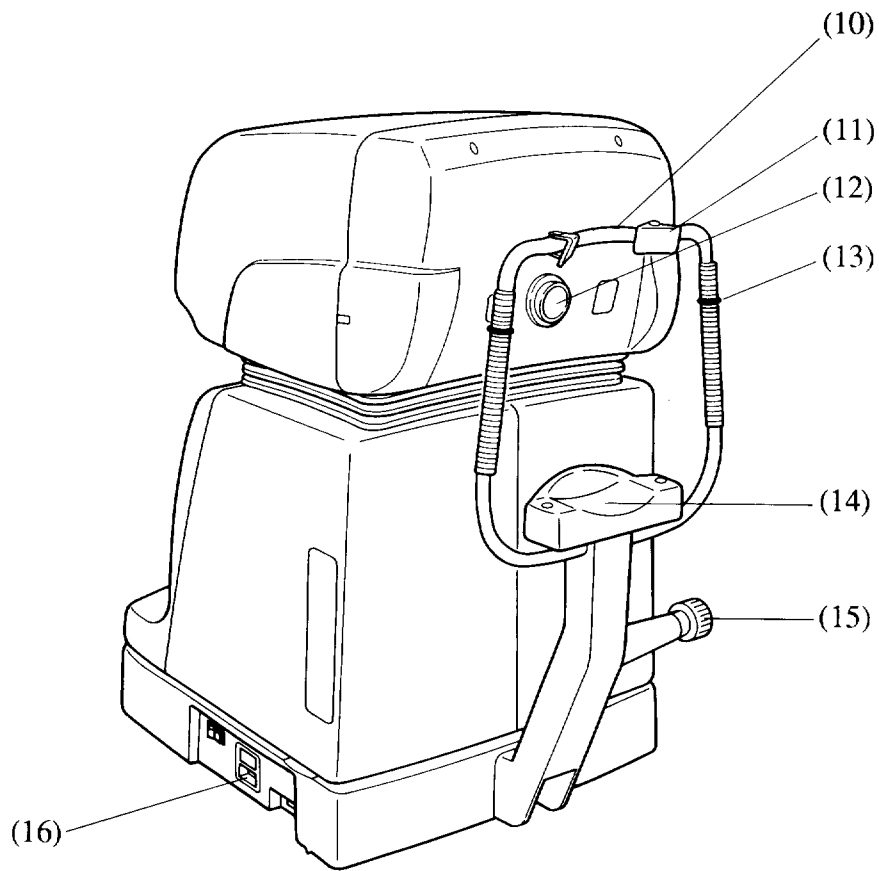

Figure 1-2

- (10) Model eye mounting hole..... Insert the model eye's pins into these holes.
- (11) Forehead rest..... The patient's forehead rests against these pads.
- (12) Measuring window..... Move the measuring head until the eye that you want to measure is in front of the window.
- (13) Height guide ring..... Align the patient's eyes parallel with these rings (see page 10).
- (14) Chin rest..... Place the patient's chin here. Chin rest paper can also be used for cleanliness.
- (15) Chin rest height adjustment.... Turn this knob to move the chin rest up or down. knob
- (16) Power supply..... Plug the power cord into the socket here (see page 4).

PRINTER AREA

Figure 1-3

- (1) Printer cover..... Remove this cover to change the printer paper roll, to adjust the brightness and contrast of the TV monitor, or to loosen or tighten the securing screws for transport.
- (2) Securing screws for..... These screws protect the instrument against vibration and shock during transport. Loosen these screws when installing this instrument, and re-tighten them whenever moving it (see page 6).
- (3) Brightness control knob..... Turn this knob to adjust the brightness of the TV monitor screen.
- (4) Contrast control knob..... Turn this knob to adjust the contrast of the TV monitor screen.

POWER SUPPLY

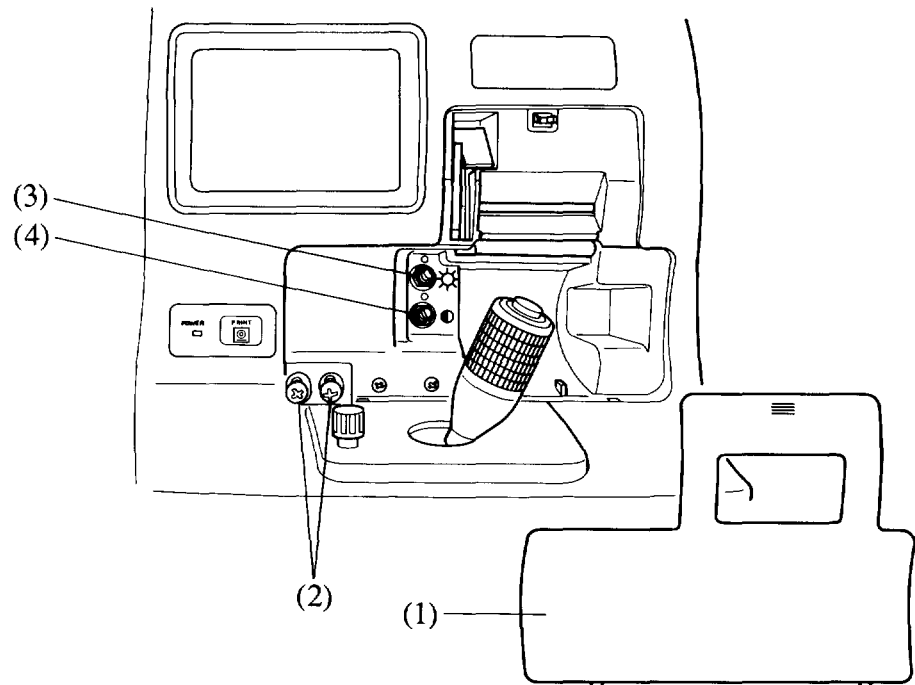
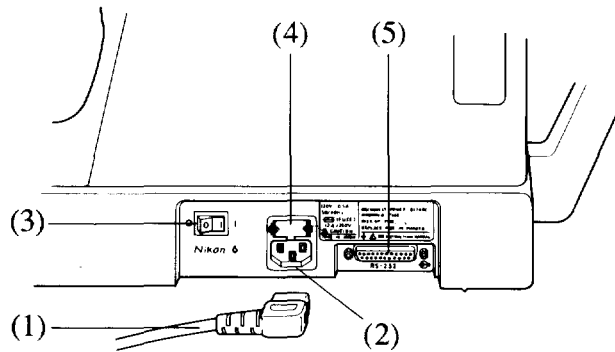

Figure 1-4

- 1) Power cable
- 2) Power cord socket..... Plug the power cord into this socket.
- 3) Power switch..... Press to the "I" position to turn on this instrument and press to the "O" position to turn it off.
- 4) Fuse holder..... Contains the fuses (see page 43).
- 5) RS-232C interface connector..Connect the interface cable of an external device (such as Nikon Auto Optester or a computer) into this connector (see page 45).

Description of icons

	Alternate current		OFF (Separation from power source)
	Fuse		ON (Connection to power source)
	Caution (Do not open the cover)		B-type instrument
	Caution (See instructions manual)		Brightness control
	Print		Contrast control
	RS-232C interface connector		

2. Preparation

2-1. Removing Screws for Transport

- (1) Before installing this instrument, loosen the four securing screws for transport (two screws each at the bottom and front) by using the Phillips screwdriver provided.
- ① Align the tabs on the both sides of the bottom of the instrument with the edge of the table on which the instrument is placed.

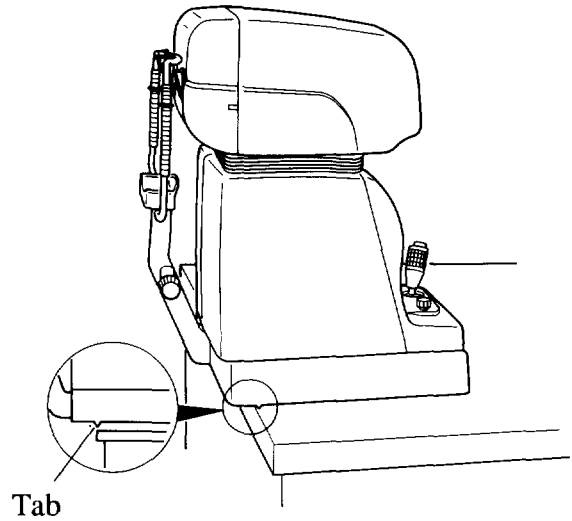

Figure 2-1

Do not pull the instrument beyond the tabs because it may possibly fall off the table.

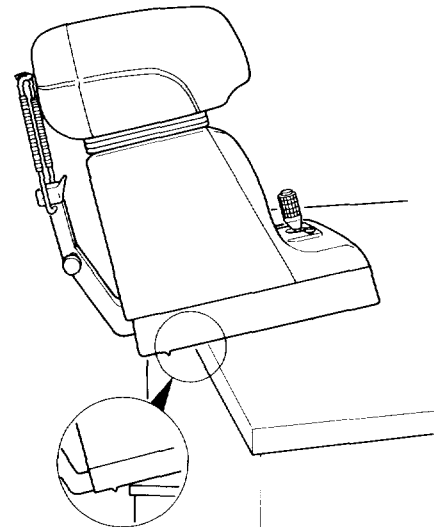

Figure 2-2

- ② Loosen the two securing screws (Phillips head type) located at the bottom of the instrument by using a Phillips screwdriver. (These screws cannot be completely removed.)

Securing screws for transport

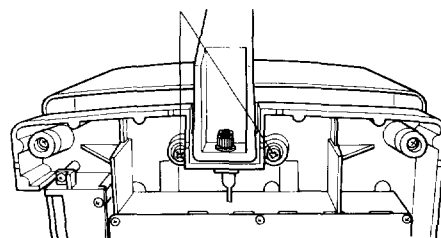

Figure 2-3

- ③ Press in on the upper section marked ≡ of the printer cover to remove it.

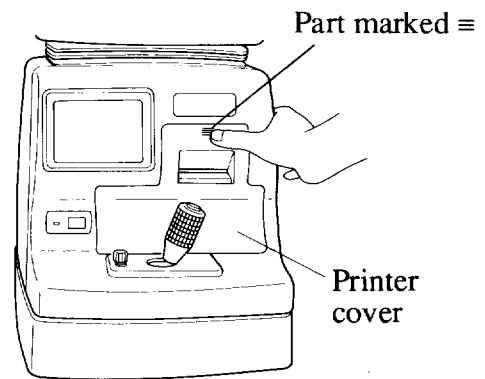

Figure 2-4

- ④ Loosen the two securing screws (Phillips head type) located at the bottom of the instrument by using a Phillips screwdriver. (It is not necessary to remove the two securing screws completely.)

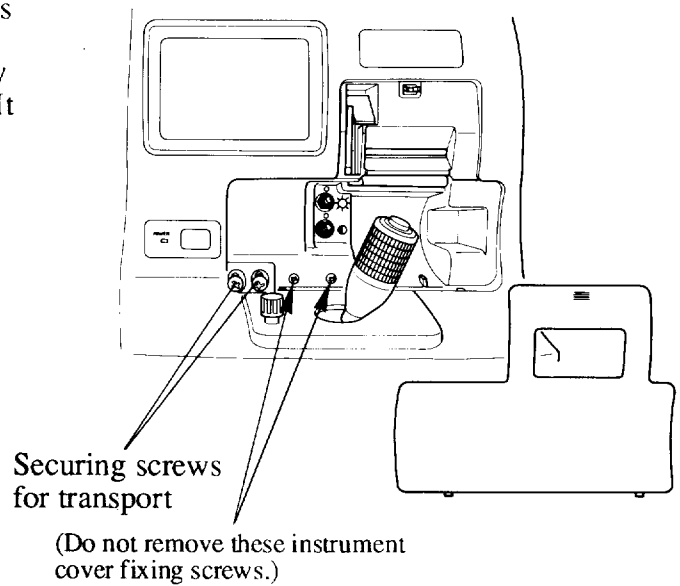

Figure 2-5

- ⑤ Pull the upper portion of the instrument to securely place it on the base.

Whenever you transport the instrument, tighten the four securing screws described in Steps ② and ④ above to prevent the internal parts from being damaged by vibration or shock. Before tightening the securing screws for transport, move the instrument in the opposite direction as shown in Figure 2-6.

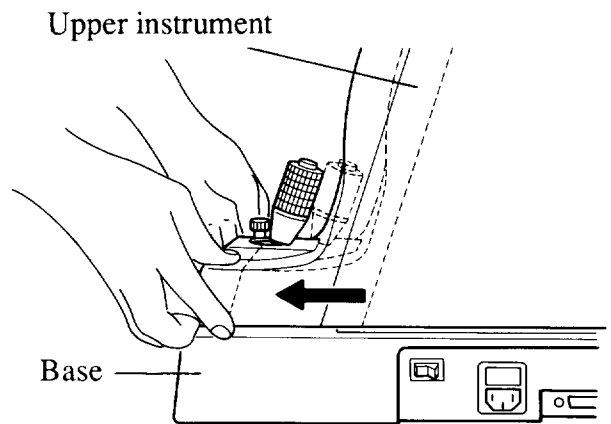

Figure 2-6

2-2. Power ON

- (1) Plug the power cord into the base.
Use the three cord retainers to secure the power cord.
- (2) Plug the power cord into the main outlet.
- (3) When you turn ON the power switch, the POWER lamp below the screen lights and the screen becomes bright.
- (4) After about 20 seconds, a "do, mi, sol, do, do, sol, mi, do" melody sounds to tell you that the instrument is ready for use.

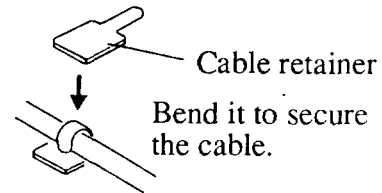

Figure 2-7

2-3. Measurement Preparation

- (1) Whenever you press the CYL on the screen, the sign of the cylindrical power changes in this cycle: CYL- → CYL+ → CYL±.

Select the display form you want.

- CYL-: CYL is always displayed with the minus sign (-).
- CYL+: CYL is always displayed with the plus sign (+).
- CYL±: CYL is always displayed in one of the following combinations:
(+) SPH (+) CYL
or
(-) SPH (-) CYL
In the case of a mixed astigmatism, CYL is always displayed with the plus sign (+).

Whenever you press the $\overline{\text{VD}}$ 13.8 on the screen, the VD (corneal vertex distance) changes in this cycle: 0.0 → 13.8
or 0.0 → 12.0 → 0.0
or 0.0 → 13.5 → 0.0
or 0.0 → 15.0 → 0.0
or 0.0 → 12.0 → 13.5 → 13.8 → 15.0 → 0.0
depending upon the pre-setting in the system data setting (see page 37).

Select either VD you want.

- 0.0: Displays values with the corneal vertex distance for contact lens wearing.
- 12.0/13.5/13.8/15.0: Displays values with the corneal vertex distance (12.0mm/13.5mm/13.75mm/15.0mm) for ophthalmic frame wearing.

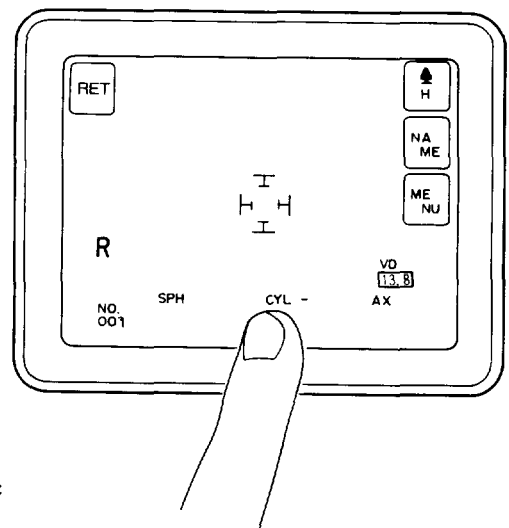

Figure 2-8

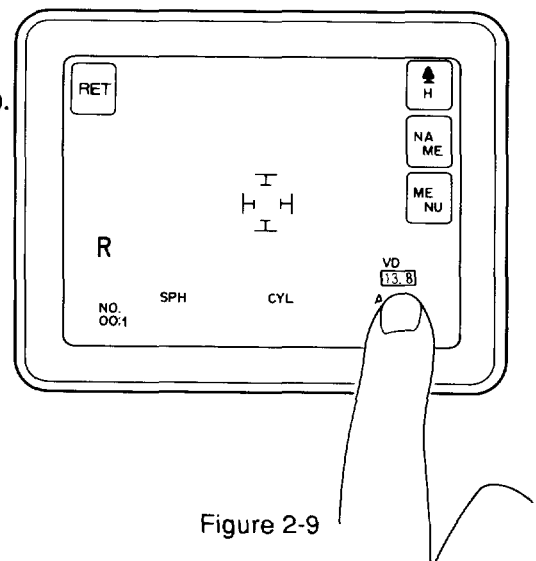

Figure 2-9

- (2) Measure the model eye provided.
- ① Set the model eye in front of the window by inserting the two pins of the model eye into the mounting holes on the forehead rest (see Figure 2-10).
When measuring the model eye, set the VD value on the screen to either 12.0, 13.5, 13.8, 15.0 (see Figure 2-9 on page 7).
 - ② For details on the measurement method, see pages 9 through 13.
 - ③ Make sure that the measured values are within the following ranges:

SPH: +4D ~ +5.75D
(CYL: 0)

If correct values are not obtained, review the measurement method and repeat the measurement sequence (see also 7-(6) on page 44).

- (3) Clean the forehead rest and chin rest with alcohol.
- (4) To install the chin rest paper, raise the two pins on the chin rest and push the paper towards the pins while the notches are aligned (with the pins) then lower the pins onto the top of the chin rest paper to secure it (see Figure 2-11).

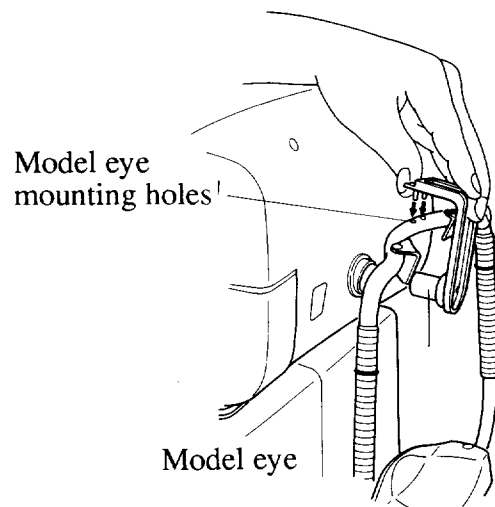

Figure 2-10

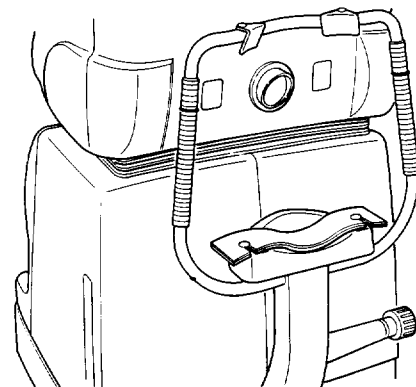
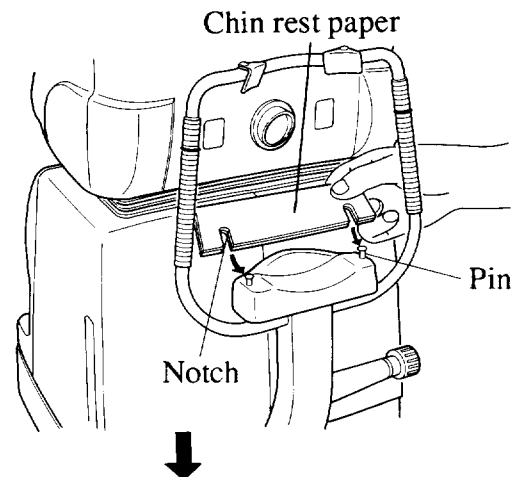

Figure 2-11

To order paper for the chin rest please contact the dealer that you purchased the instrument from or the nearest Nikon distributor.

3. Measurement Method

(1) Refraction Measurement

After turning the unit ON, the "do, mi, sol, do, do, sol, mi, do" melody sounds and the measurement screen is displayed.

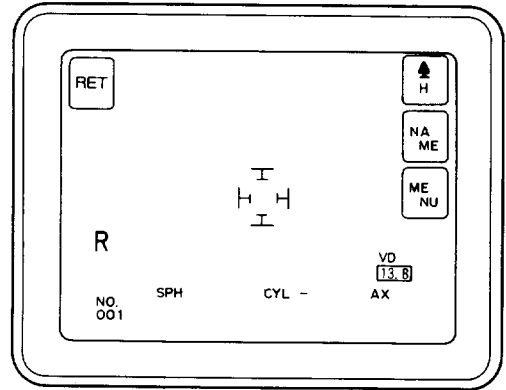

Figure 3-1

(1) Before measurement

Most patients will be rather nervous, so try to put them at ease. Briefly explain the units operation and purpose to the patient:

- 1) "This machine measures the power of the spectacle lenses you should use."
- 2) "You will see a green field. Please look at the tree in the center, with your eye in a relaxed manner."
- 3) "Try to keep your eye as still as possible."

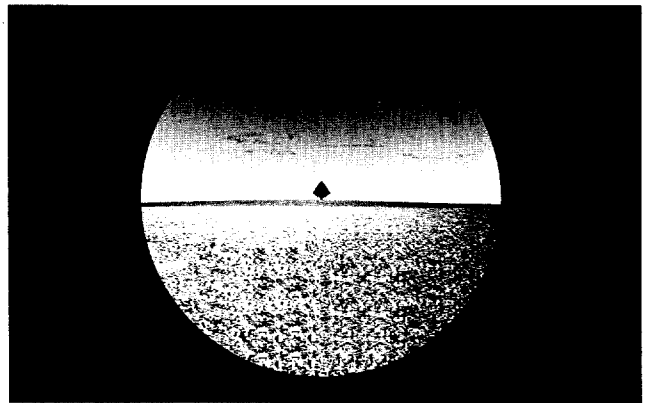

Figure 3-2
Target Seen by the Patient

(2) Measurement procedure

- ① Show the patient where to sit. Ask the patient to rest both the hands on the lap (see Figure 3-3).

Adjust the height of the chair or the table so that the patient is comfortable.

Turn the chin rest height adjustment knob to align the patient's eye parallel with the height guide rings.

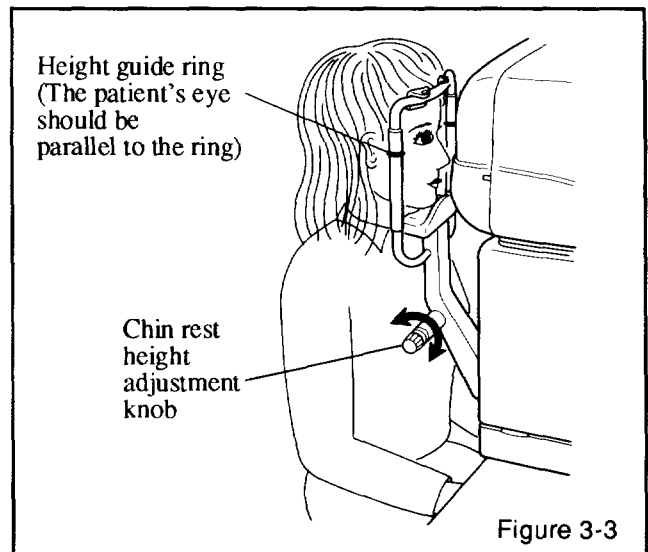

Rest the patient's chin firmly on the chin rest; otherwise the following situations may happen.

- Flickering spot does not become smaller as Figure 3-8.
- Auto fogging OK mark ($\rightarrow * \leftarrow$) does not appear.
- Measurement result is incorrect.

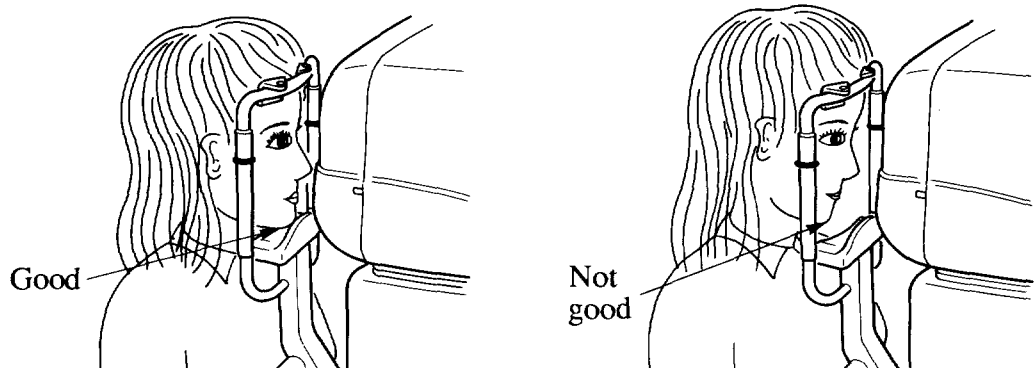

- ② Move the joystick lever to position the measuring head so that the patient's eye is displayed on the screen (you may measure either eye first).

- Vertical movement: Turn the joystick lever.
- Horizontal movement: Tilt the joystick lever.

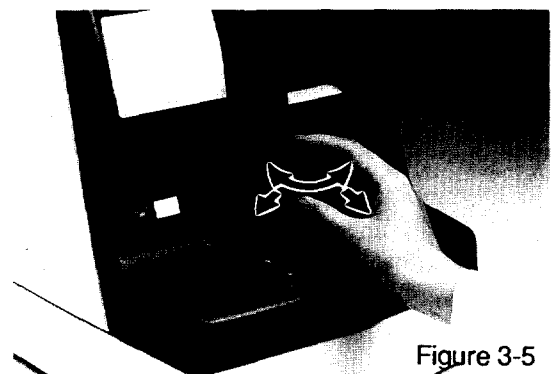

To quickly display the patient's eye on the screen (see Figure 3-6):

- Vertical:
Align the head height mark with the height guide ring located on the chin rest bar.
- Horizontal:
Align the edge of the sliding seat with the target line on the base.

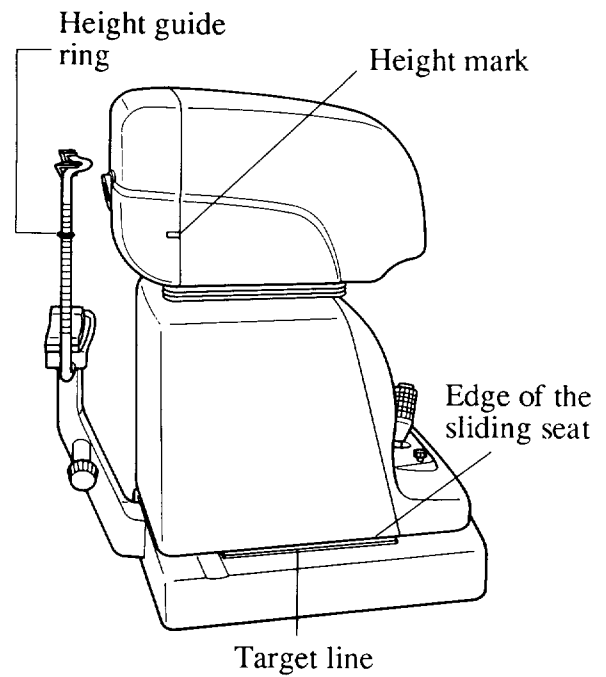

Figure 3-6

When the patient's eye image is coming into the screen, move it to the center.
Align the flickering dot with the center of the alignment mark (see Figure 3-7).

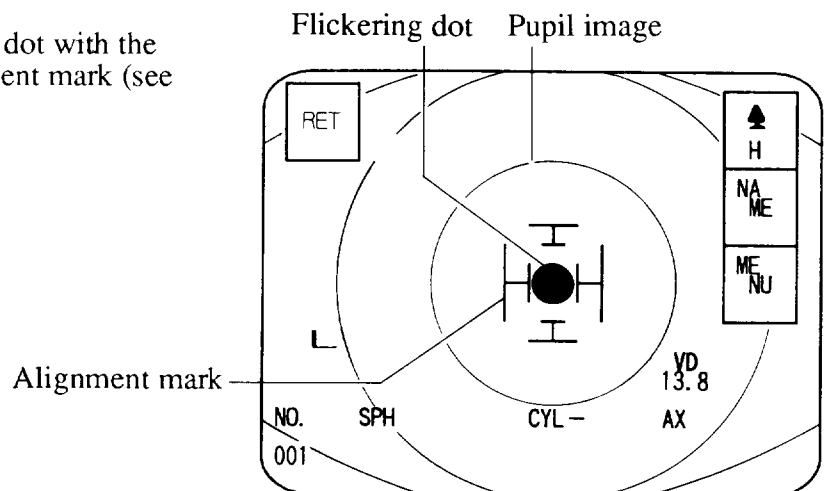

Figure 3-7 Align the Flickering Dot with the Center of the Alignment Mark

- ③ While aligning the flickering dot as described in Step ② above, tilt the joystick lever back and forth until the flickering dot becomes as small as possible (the internal patient target comes slightly toward the plus side from the far point of the patient's eye and the auto fogging OK mark (→*←) will appear) (see Figure 3-8).

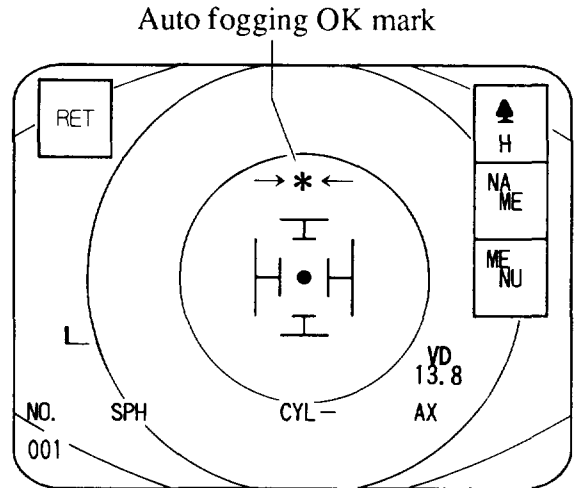
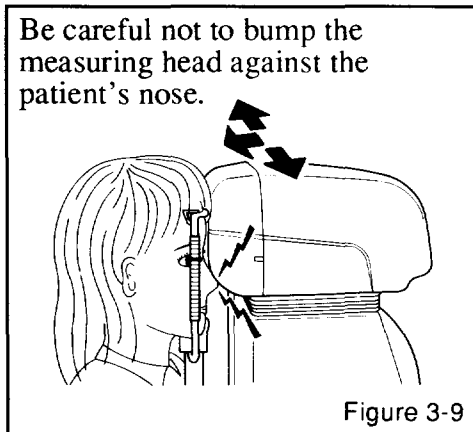

Figure 3-8 Adjust the joystick lever so that the flickering dot becomes as small as possible.

- ④ When the auto fogging OK mark (→*←) appears at the center of the screen, press the start button (see Figure 3-10).

The instrument performs the automatic fogging and then completes refraction measurement in about 0.2 of a second.

Turn clockwise the measuring base hold-down knob to lightly tighten it. This makes the flickering dot difficult to move away from the center of the alignment mark while taking multiple cycles of measurement (see Step ⑥ on page 13).

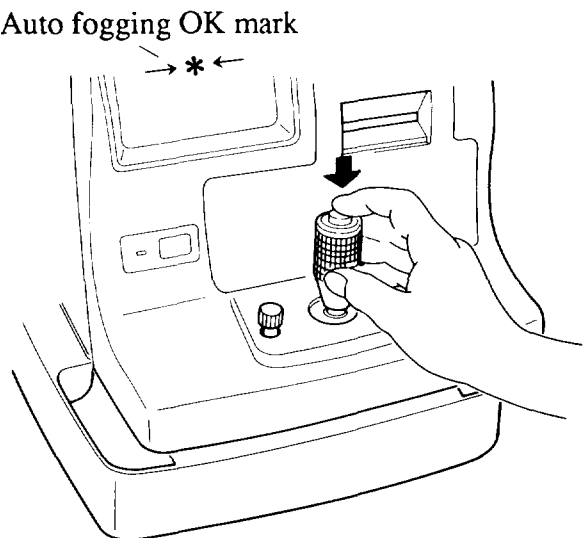

Figure 3-10

(When you specify a two or greater number for REF REPEAT on the SYSTEM DATA SET screen (see page 37), keep hold down the start button. The refraction measurement is repeated the specified number of times.)

If the auto fogging OK mark (→*←) does not appear, the patient cannot see the target well and the automatic fogging (see page 14) will not function properly. Re-align the flickering dot with the center of the alignment mark.

When it is not possible to make the auto fogging OK mark (→*←) appear by any means (in case of cataract patient, for example), press the start button when the flickering dot becomes smallest.

- ⑤ Measured values are displayed on the screen (see Figure 3-11).
- ⑥ Take approximately five measurements (or more for patients who move their eyes a lot or when measured values vary over a wide range) for each eye.

When taking multiple cycles of measurement, after the measured values are displayed, again perform alignment and make sure that the auto fogging OK mark (→*←) appears before starting the next cycle of measurements.

Only measured values of the previous 20 measurement cycles for each eye are stored.

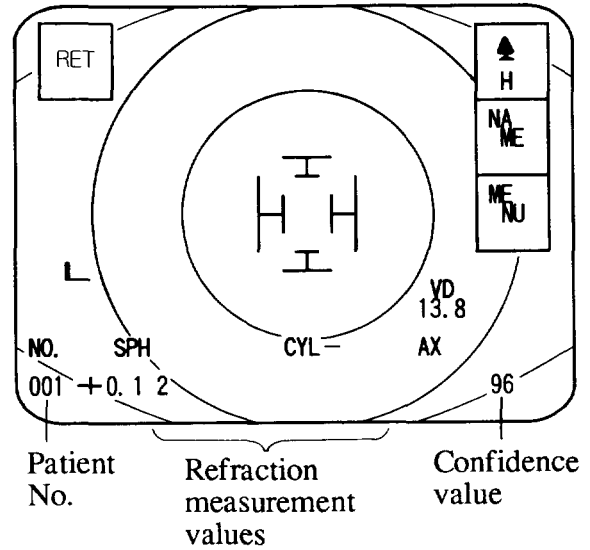

Figure 3-11
Measurement Display (After One Eye is Measured)

- ⑦ After measuring one of the patient's eyes, measure the other in the same way.

Pull the measuring head backward by the joystick lever along the line marked at the base before sliding the measuring head side to side, otherwise it may bump against the patient's nose.

Make this part trace the line

Right/left positioning guide line

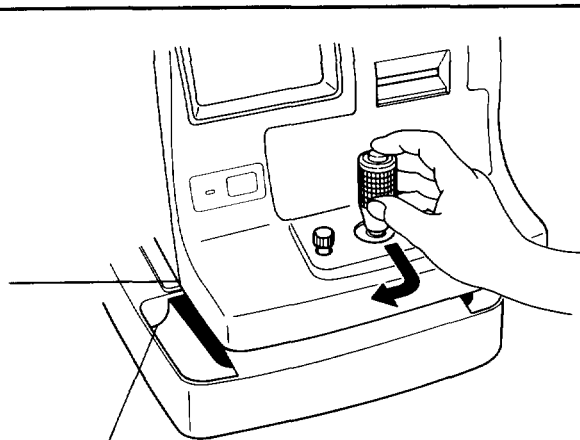

Figure 3-12

- ⑧ After both eyes have been measured, the PD (pupil distance in mm) value will appear above the confidence value (see Figure 3-13).

You may obtain a false PD value, if the patient's head moves or if the binocular function of the patient is not good.

In NR-5500, when the flickering dot flashes, the entire pupil brightens. If there are foreign matters shading the light (such as an opacity in the crystalline lens caused by cataract, other opacity or scratches) in the pupil, black shadows will be seen. In this case, observe the pupil in the retro illumination setting (see page 21) and proceed to further examination using the slit lamp.

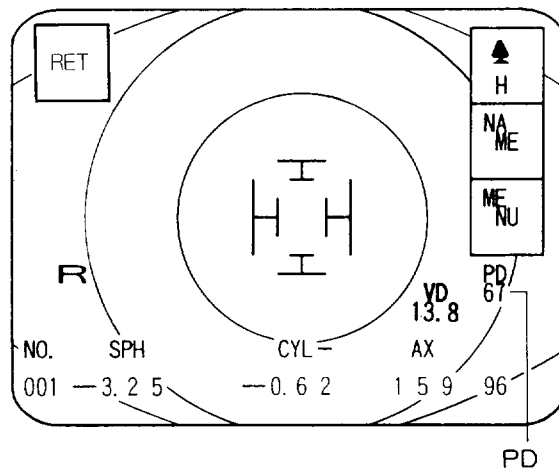

Figure 3-13
Measurement Display
(After Both Eyes are Measured)

Automatic Fogging Mechanism

The automatic fogging mechanism facilitates the patient eye fixation and will minimize the eye accommodation.

When you press the start button, a short beep sounds. The chart slightly blurs during the automatic fogging.

↓

Then, the instrument performs the measurement for approximately 0.2 second while beeping.

When this beeping stops, the measurement is complete.

↓

The patient target is then positioned to a clearly visible point.

↓

Then the patient target moves and blurs. The auto fogging OK mark (→ * ←) appears on the screen and the instrument is ready to start the next measurement.

You can cancel the automatic fogging mechanism (see page 38).

IOL patient

Your can measure IOL patient without switch changeover.

Error Messages

The following table summarizes possible error messages and causes:

Error message	Alarm	Printout	Possible causes
E		The measurement results will be printed.	<ul style="list-style-type: none"> • Eyelashes interference • Blinking • Irregular astigmatism • Cataract • Small pupil <p style="text-align: right;">Confidence value is less than 70.</p>
AL ERROR	Three consecutive beeps will sound.	No printout	<ul style="list-style-type: none"> • Incorrect positioning • Movement of the patient's eye
OVER RANGE	Three consecutive beeps will sound.	No printout	<ul style="list-style-type: none"> • Refraction exceeds the measurement range. • Pupil diameter is too small

- If a patient has drooped eyelashes, it will be necessary to make the eyelashes stay out of the outer line on the alignment mark on the screen.
If necessary, have the patient or an assistant gently lift the eyelid with their fingertip.
- Blinking during the measurement causes an automatic re-measurement. (The measurement time is extended correspondingly.) However, when people blink they generally move their eyes, and the measurement result may be affected. It is a good practice to press the start button  immediately after the patient blinks.
- The measurement cannot be made if the patient is suffering from an eye disease such as a cataract, abnormal retina, opaque condition of cornea, crystalline lens or vitreous body.
- When the pupil is much smaller than $\phi 2.9\text{mm}$, you must lower the brightness of the patient target (see page 23) and re-measure.
If the pupil is completely contained by the outer lines of the alignment mark, the pupil size is smaller than $\phi 2.2\text{mm}$.
- When $\langle S+C \rangle$ is stronger than $-18\text{D} \sim +23\text{D}$, or when $\langle C \rangle$ is stronger than $-12\text{D} \sim +12\text{D}$, measurement cannot be made because these values are beyond the measurement range.

Others

- Measurement with a contact lens on: Measurement is possible. However, if the contact lens is not properly fitted, the correct values may not be obtained. Any contamination or damage to the contact lens surface may result in measurement failure.
- Measurement with glasses on: Measurement is possible if the lens is at a slight incline. If the lens is at a large incline, correct values will not be obtained. If the light is reflected from the lens surface into the measuring head, or if the glasses have a colored lens of low transmission, the measurement may fail.

(2) Printout

- ① After the measurement process, press the [PRINT] switch.

Data is printed out according to the setting on the SYSTEM DATA SET screen (see page 37).

REF PRINT	ALL:	Prints out refraction measurement data and representative values.
	REP:	Prints out representative values of the refraction measurement.
	NONE:	Does not print out the refraction measurement data.

Representative values are also listed (see page 19).

- Only the measured values of the last 20 measurement cycles for each eye are printed out.
- If the number of measurement cycles exceeds 20, representative values are selected from the measured values of the last 20 measurement cycles taken.
- Measurement cannot be performed during printout.

- ② Cut the paper.

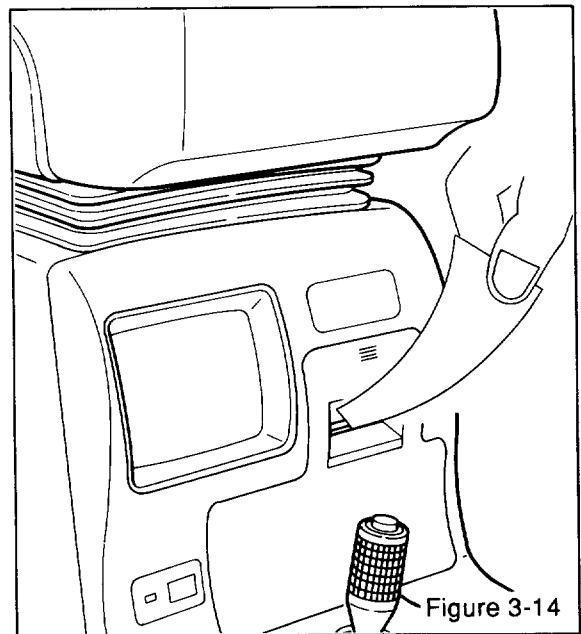

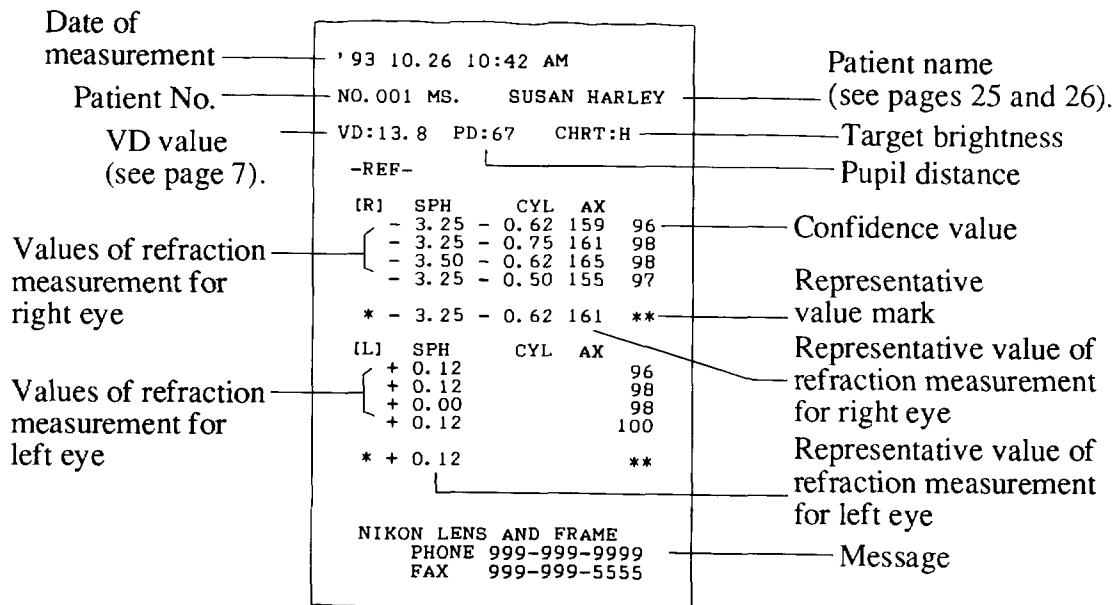

Figure 3-15 Printout from Measurement Screen

(When specifying REF PRINT = ALL and MESSAGE = ON on the SYSTEM DATA SET screen (see page 37))

- ③ The $\begin{matrix} \text{EYE} \\ \text{PRT} \end{matrix}$ key will appear in the lower right hand part of the screen (see Figure 3-16).

Press this key to print out the eye diagram (see Figure 3-17).

The eye diagram printout is retained until the next measurement is started. If the eye diagram is required, press this key before starting the next measurement.

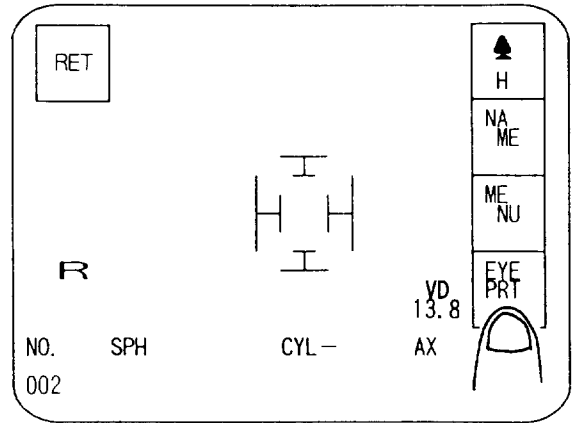

Figure 3-16

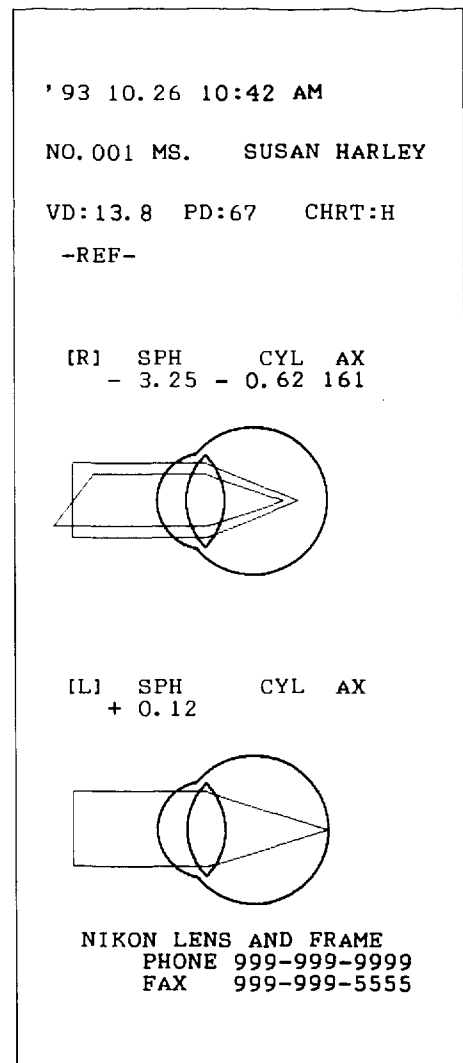
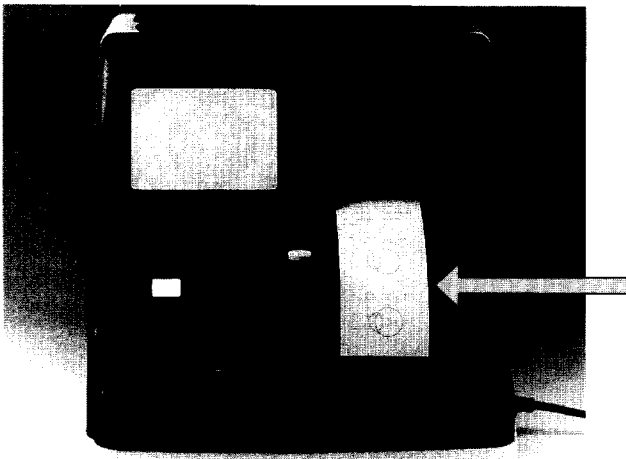

Figure 3-17 Printout of Eye Diagram

Representative Values

Example:

-REF-				
[R]	SPH	CYL	AX	
-	3.25	- 0.62	159	96
-	3.25	- 0.75	161	98
-	3.50	- 0.62	165	98
-	3.25	- 0.50	155	97
*	- 3.25	- 0.62	161	**

Figure 3-18

An asterisk (*) indicates the representative values on a printout.

Representative value: A guide to help you choose which one of the several measured values for one eye to use. The representative values do not include a confidence value.

When selecting from one of the measured refraction values that vary widely, consider the following:

- **Substantial variance of SPH values**
The patient's eye may be accommodating. Select the largest plus value. It is also advisable to re-measure the eye several times.
- **Substantial variance of CYL and AX values**
The AX values will tend to somewhat vary when the eye is weak astigmatic (CYL value of less than 0.5D). Other causes include:
 - Eyelashes are occluding the pupil.
 - The pupil diameter is less than $\varnothing 2.9\text{mm}$.
 - An opaque eye or an irregular astigmatic.
 When any of the above three situations occurs, normally a low confidence value will be reported. If the eyelashes or pupil diameter affect the measurement, you should re-measure the eye paying close attention to these factors.

Storing Representative Values of Refraction Measurement

- Only the representative values of the refraction measurement for up to 300 patients can be stored. If an excess of representative values are stored, the older data will be deleted.
- When you press the [PRINT] switch on the measurement screen, the instrument determines that the measurement is finished and stores the representative values of refraction measurement for the patient.
- The representative values are not stored until you press the [PRINT] switch. When you set the REF PRINT to ALL or REP on the SYSTEM DATA SET screen (see page 37), the representative values will be automatically stored after printing. When you set REF PRINT to NONE, the instrument will not print data but stores the representative values.
- After the instrument stores the representative values, it is ready to start the next measurement. The patient No. will increase by one.
- Even after you have measured only one eye, the representative values of refraction measurement can be stored.
- The stored data items include: patient No., date of the measurement, the representative values of refraction measurement (SPH, CYL and AX), PD and used VD values, and the data input from the name entry screen (see pages 25 and 26).

Confidence Value

Example:

R			
NO.	SPH	CYL -	AX
001	-3.2 5	-0.6 2	1 5 9 96

VD
13.8

Figure 3-19

The values in the above screen are the results of the refraction measurement of the right eye and are read as follows:

Spherical power: -3.25, Cylindrical power: -0.62, Cylindrical axis: 159, Confidence value: 96

The confidence value is a guide for evaluating the results of measurement and is displayed at the end of the sequence of measured values.

- "90 or more" is desirable.
- "85 or more" is normal.
- "Less than 85" means that something has affected the measuring beam. Perform some more cycles of measurement.
- "Less than 70" is abnormal. "E" will be displayed (confidence value is output on a printout) (see page 15).

4. Enhanced Retro Illumination Setting

This mode allows you to observe the inside of a pupil more easily, and check the measurements if the measured values vary, or the confidence value is low.

- ① Press the [RET] key to enter the retro illumination setting mode. If foreign matter intercepts the measurement light, it can be seen as a black shadow on the screen. (Fig. 4-1)

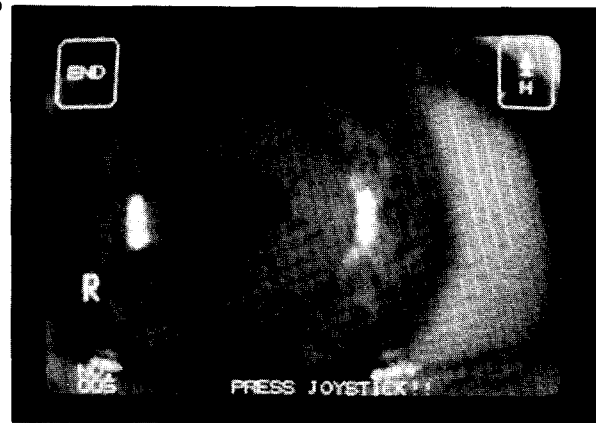

Figure 4-1 Retro Illumination after Touching [RET] key

- ② Find a position where the foreign matter in the pupil can be seen clearly, and then press the start button. This allows you to observe the inside of the pupil for about two seconds on the screen as shown in Figure 4-2.

The center dot remains on for two seconds after the start button is pressed, and then starts flickering, but the anterior segment illumination (which brightens the eyelid or the surface of pupil) remains off.

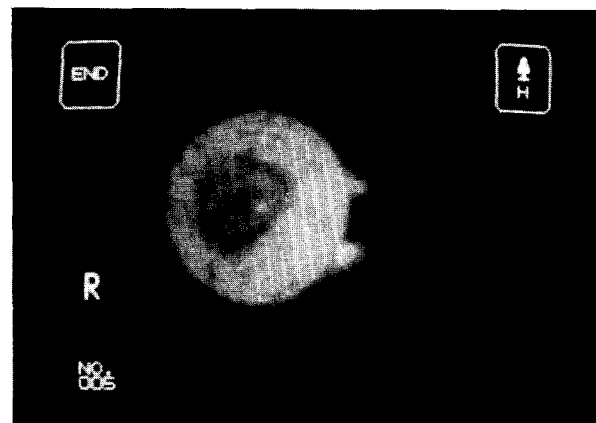

Figure 4-2 Enhanced Retro Illumination Image (Dynamic Image)

- Press the [PRINT] switch to turn on the anterior segment illumination.
 - When the anterior segment illumination switches off, it is turned on by moving the measuring head from the left eye to the right or vice versa.
- Foreign matter in the pupil may be more clearly seen if the center is varied slightly. In particular, an opacity at the center may not be visible unless the light is directed in from the edge of the pupil.
 - If some type of external illumination such as a fluorescent room lamp enters the patient eye, foreign matters in pupil may not be visible.

Press the [END] key to return to the measurement mode.

5. Touch Panel

(1) Measurement Screen

1. CYL transposition

Whenever you press the CYL on the screen, the sign of the cylindrical power changes in the following cycle:

CYL- → CYL+ → CYL±.

Select the display form you want.

2. VD conversion

Whenever you press the $\overline{\text{VD}}$ $\overline{13.8}$ on the screen, the VD (corneal vertex distance) changes in the following cycle (see pages 7 and 37).

0.0:

Measured values are converted based on the corneal vertex distance for contact lens wearing (0.0mm).

12.0/13.5/13.8/15.0:

Measured values are converted based on the standard corneal vertex distance for ophthalmic lens wearing (12.0mm/13.5mm/13.75mm/15.0mm).

3. Target brightness control key

Press this key to adjust the brightness of the target the patient sees. Determine the brightness according to the size of the patient's pupil (see page 15).

[H] $\begin{matrix} \rightarrow \\ \leftarrow \end{matrix}$ [M] $\begin{matrix} \rightarrow \\ \leftarrow \end{matrix}$ [L]

H: High
M: Medium
L: Low

4. [NAME] key

Press this key to display the name entry screen (see pages 25 and 26).

5. [MENU] key

Press this key to display the menu screen (see page 27).

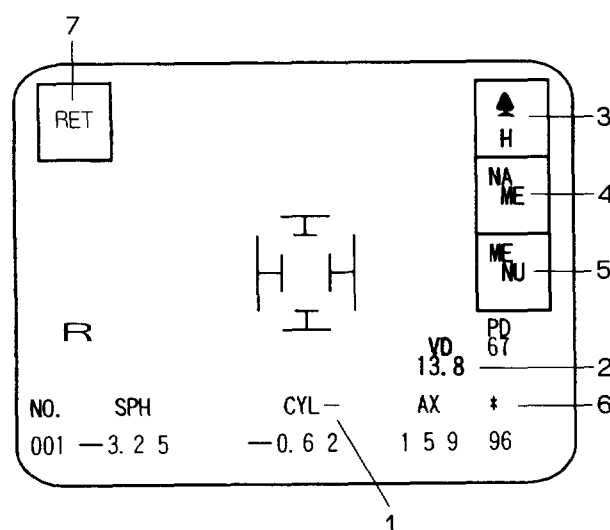

Figure 5-1 Measurement Screen

6. Check mark

When you touch the confidence value on the measurement screen, a check mark (*) will appear (see Figure 5-1). This mark is useful to identify an eye that you want to distinguish from others during a measurement sequence. Touch the same area again to erase the mark.

Displaying this mark before pressing the [PRINT] switch can store the mark.

This mark can be added to either the right- or left-eye data of the same patient.

This mark is also displayed on the LIST screen (see page 28).

For example, you may use this mark to distinguish particular data items so that they can be re-inspected. This feature is useful if the measurement results are not stable or if there is any abnormality in the image on the screen during group examination or otherwise.

7. The retro illumination setting key

Press this key to display retro illumination setting screen (see page 21).

(2) Name Entry Screen

(Patient name or ID number of up to 14 characters can be entered.)

- ① Press the [NAME] key on the measurement screen (see pages 9 through 14) to display the patient name entry (A-Z) screen (see Figure 5-2).

On this screen, alphabetic characters (A-Z) can be entered.

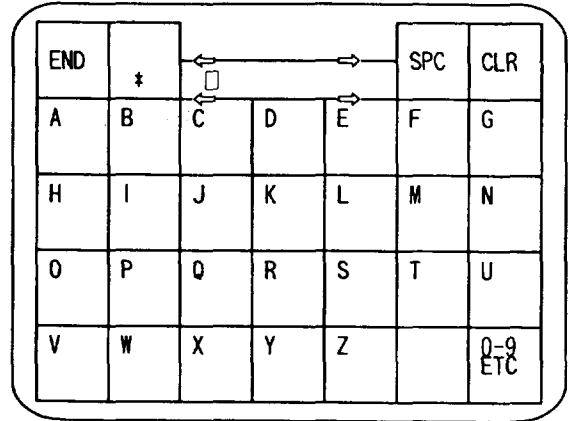

Figure 5-2 A-Z Entry Screen

- Press the $\begin{bmatrix} 0-9 \\ \text{ETC} \end{bmatrix}$ key on the A-Z entry screen to display the 0-9/ETC entry screen.

On this screen, numbers and special characters can be entered.

② Use the character keys to enter a patient name or ID number.

- To enter a title, use the [*] key. Whenever you press this key, the title changes in the following cycle: * (no title) → MR. → MS. → MRS. → MISS.

- To correct an entered character, press the the arrow mark:

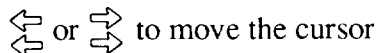

onto the character (Figure 5-4) and enter a correct character.

- To make a space before entering a next character, press the [SPC] key.
- To clear all entered characters, press the [CLR] key.

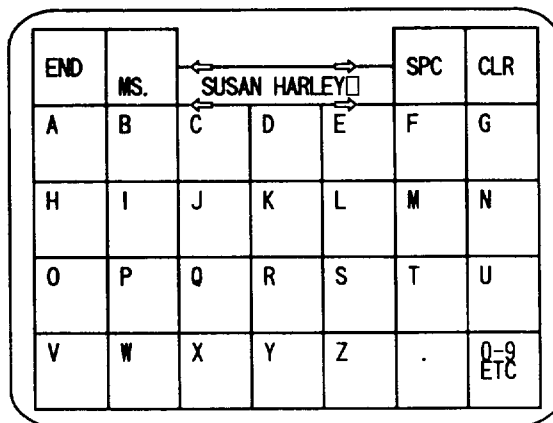

Figure 5-3 Name Entry Screen After a Patient Name is Entered

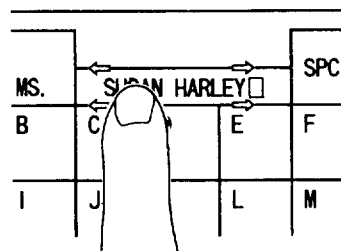

Figure 5-4 Depress Arrow for Correction

③ When entry is completed, press the [END] key.

The measurement screen will return.

The entered patient name or ID number is displayed on the measurement screen (see Figure 5-5).

The entered patient name or ID number is printed out or stored with the measured values.

If you have not entered a patient name or ID number, only NAME: will be printed.

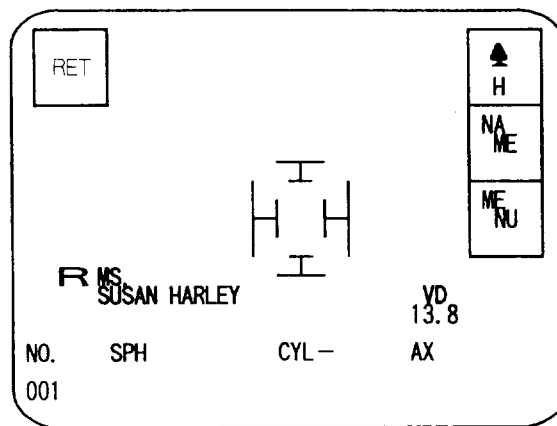

Figure 5-5 Measurement Screen After a Patient Name is Entered

(3) Menu Screen

Press the [MENU] key on the measurement screen (see pages 9 through 14) to display the menu screen (see Figure 5-6).

Press one of the five keys except the [END] key to display a corresponding screen as described in (3)-1 through (3)-5 on the following pages.

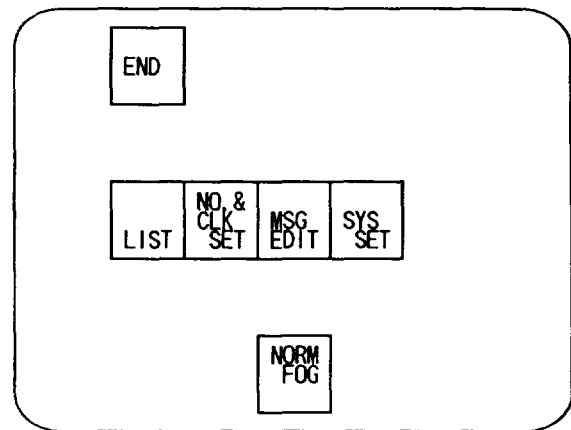

Figure 5-6 Menu Screen

(3)-1 Memory Data List Screen

(To view, edit or send the measured data list)

Press the [LIST] key on the menu screen (see page 27 and Figure 5-6) to display the LIST screen (see Figure 5-7).

- The LIST screen displays the entered patient No., date of measurement, representative values for right and left eyes (for one eye only when only one eye has been measured), and PD and VD values.

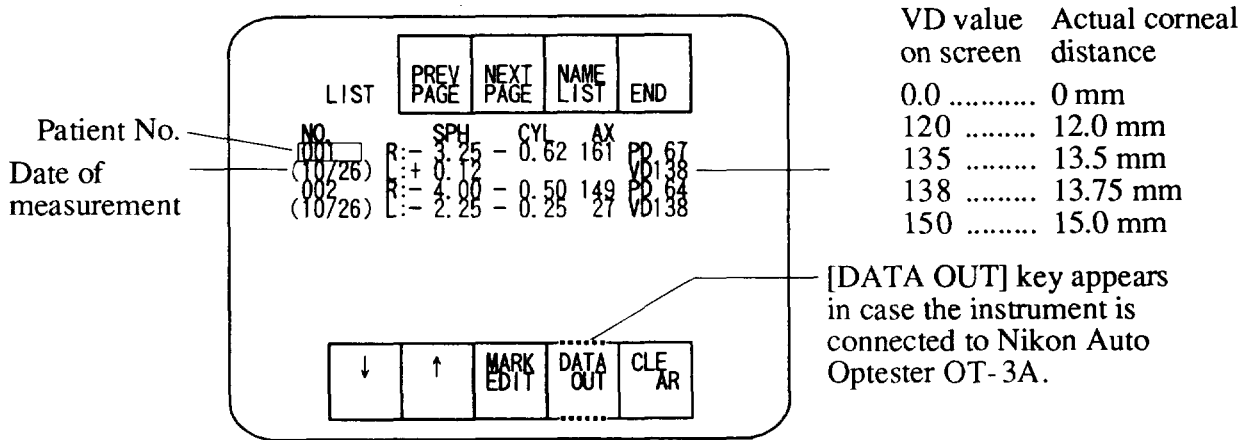

Figure 5-7 List Screen

- Press the [NAME LIST] key to display the NAME LIST screen. On this screen, the entered patient names and other information are displayed instead of the measured values (see Figure 5-8).

Press the [LIST] key on the NAME LIST screen to return to the LIST screen.

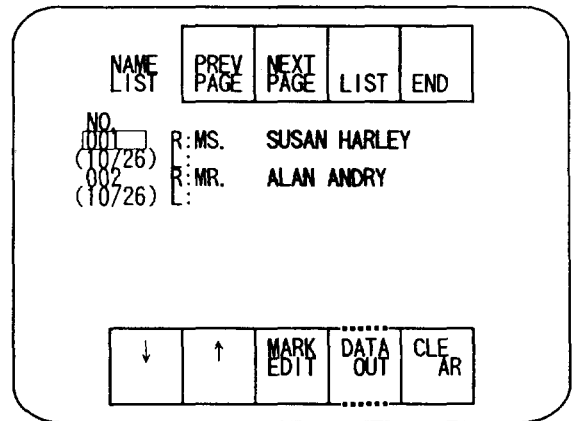

Figure 5-8 NAME LIST Screen

- The LIST or NAME LIST screen can display data for up to seven patients. To display another page:

Press the [PREV PAGE] key to display the previous page.

Press the [NEXT PAGE] key to display the next page.

Press the [↓] or [↑] key to scroll the display by the data for each patient.

LIST PRINT screen

- ① Press the [PRINT] key on the LIST screen (see page 28 and Figure 5-7) or the NAME LIST screen (see page 28 and Figure 5-8) to display the LIST PRINT screen (see Figure 5-9).
- ② Press the [↓] or [↑] key to move the cursor to the data you want to print.

The list data or patient names are printed out as follows:

(A sample printout is shown in Figure 5-10 on the following page.)

LIST PRINT					LIST	END
NO		SPH	CYL	AX	PD	67
(001)	R:-	3.25	- 0.62	161	VD1	38
(10726)	R:+	0.12	- 0.50	149	PD	64
002	R:-	4.00	- 0.50	149	PD	64
(10726)	L:-	2.25	- 0.25	27	VD1	38

↓	↑	ONE	PAGE	ALL
---	---	-----	------	-----

Figure 5-9 LIST PRINT Screen
(Displayed from LIST Screen)

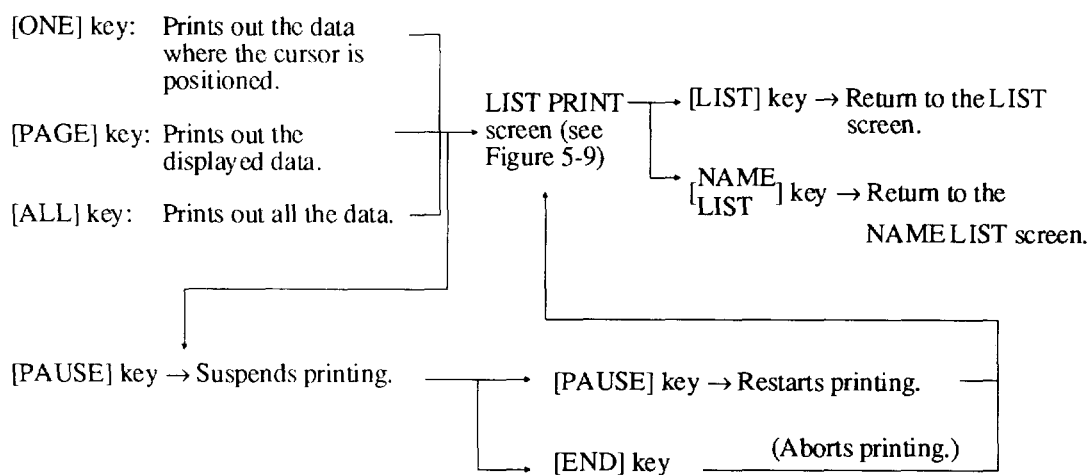

To return to the measurement screen, press the [END] key.

```
'93 10.26 11:17 AM
----- LIST PRINT -----
NO.009 (10/26)
R:- 3.00 - 1.37 14 PD 66
L:- 2.00 - 0.25 34 VD138
NO.010 (10/26)
R:- 1.75 - 0.50 170 PD 65
L:- 2.00 VD138
NO.011 (10/26)
R:- 3.50 - 1.00 161 PD 64
L:+ 0.00 - 0.25 23 VD138
NO.012 (10/26)
R:- 1.50 PD 66
L:- 2.50 - 0.75 69 VD138
NO.013 (10/26)
R:- 2.25 - 0.62 103 PD 65
L:- 1.00 - 0.37 13 VD138
NO.014 (10/26)
R:- 3.00 - 0.50 4 PD 65
L:- 1.25 - 0.25 60 VD138
NO.015 (10/26)
R:- 1.00 - 0.37 71 PD 64
L:- 0.75 - 0.87 58 VD138
```

Figure 5-10 Sample Printout Output from LIST PRINT Screen

MARK EDIT screen

(To edit the referenced mark % and the check mark *)

- ① Press the $\left[\begin{array}{c} \text{MARK} \\ \text{EDIT} \end{array} \right]$ key on the LIST screen (see page 28 and Figure 5-7) or the NAME LIST screen (see page 28 and Figure 5-8) to display the MARK EDIT screen (see Figure 5-11).
- ② Press the $[\downarrow]$ or $[\uparrow]$ key to move the cursor to the line you want to edit.

Referenced mark
Check mark

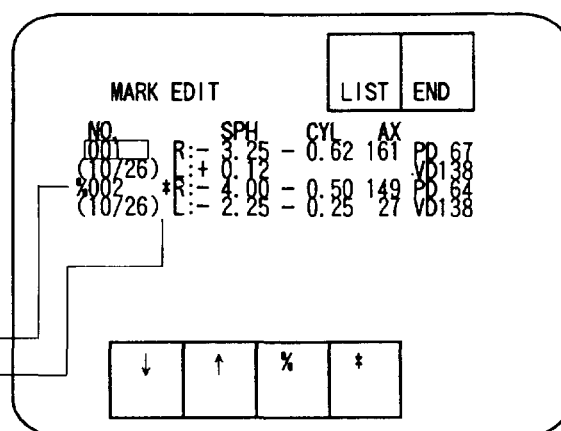

Figure 5-11 MARK EDIT Screen

To edit a referenced mark %, press the [%] key. The [MARK] key will appear at the bottom of the screen. Each time you press the [MARK] key, the referenced mark % will appear or disappear.

Note on the Referenced Mark %

When the NR-5500 is connected with the Nikon Auto Optester OT-8A, this mark will appear automatically upon completion of the measurement with the OT-8A. While this mark is displayed, data is not sent to the OT-8A. To re-send data to the OT-8A, press the [%] key to clear the % mark.

To edit a check mark *, press the [*] key. The [MARK] and $[R \leftrightarrow L]$ keys appear at the bottom of the screen. Use the $[R \leftrightarrow L]$ key to select a line for the right or left eye. Each time you press the [MARK] key, the check mark * will appear or disappear on the selected line.

Note on the Check Mark *

The check mark * can be placed on the measurement screen. This mark can be added to either right- or left-eye data of the same patient (see page 24).

To return to the LIST or NAME LIST screen, press the [LIST] or $\left[\begin{array}{c} \text{NAME} \\ \text{LIST} \end{array} \right]$ key.

To return to the measurement screen, press the [END] key.

LIST DATA OUTPUT screen

(Use this screen to send data to the Nikon Auto Optester OT-3A via the RS- 232C interface connector. When a direct connection with the OT-7A/OT-8A is established, this screen will not be displayed.)

- ① Press the $\left[\begin{matrix} \text{DATA} \\ \text{OUT} \end{matrix} \right]$ key on the LIST screen (see page 28 and Figure 5-7) or the NAME LIST screen (see page 28 and Figure 5-8) to display the LIST DATA OUTPUT screen (see Figure 5-12).
- ② Press the $[\downarrow]$ or $[\uparrow]$ key to move the cursor to the data you want to send.

List data or patient names are sent as follows:

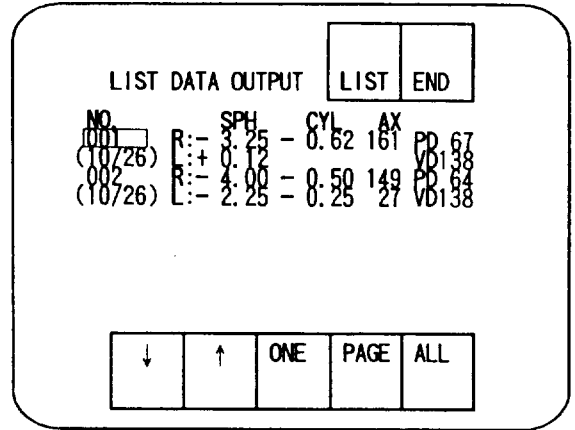
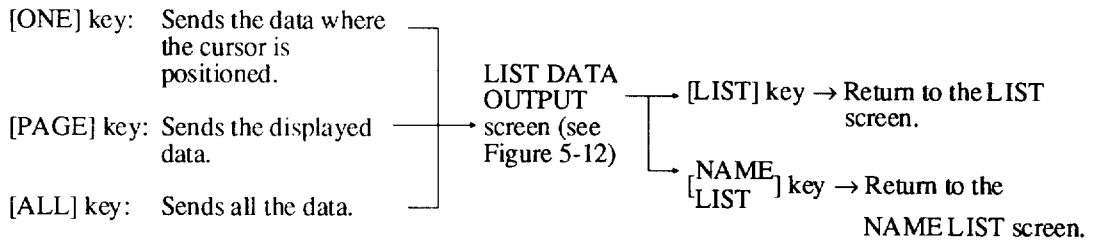

Figure 5-12 LIST DATA OUTPUT Screen



To return to the measurement screen, press the [END] key.

LIST CLEAR screen

(To clear stored data)

- ① Press the [CLEAR] key on the LIST screen (see page 28 and Figure 5-7) or the NAME LIST screen (see page 28 and Figure 5-8) to display the LIST CLEAR screen (see Figure 5-13).
- ② Press the [↓] or [↑] key to move the cursor to the patient No. you want to clear.

List data or patient names are cleared as follows:

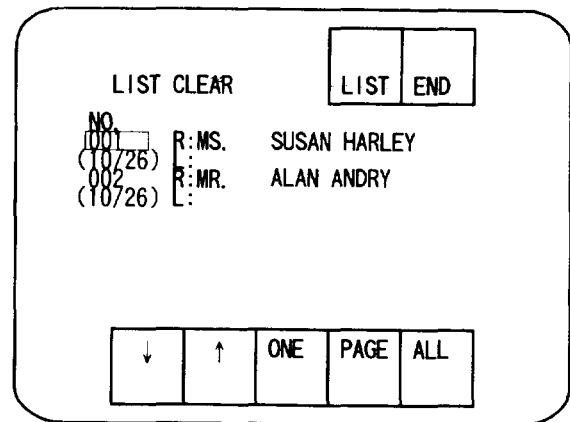
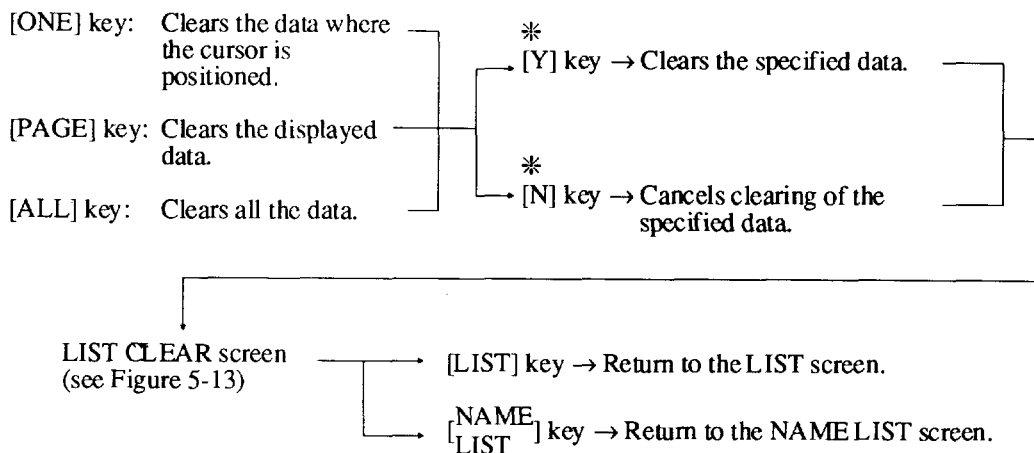

Figure 5-13 LIST CLEAR Screen (For Name List)



* The [Y] and [N] keys will appear when you press the [ONE], [PAGE] or [ALL] key (see Figure 5-14).

To return to the measurement screen, press the [END] key.

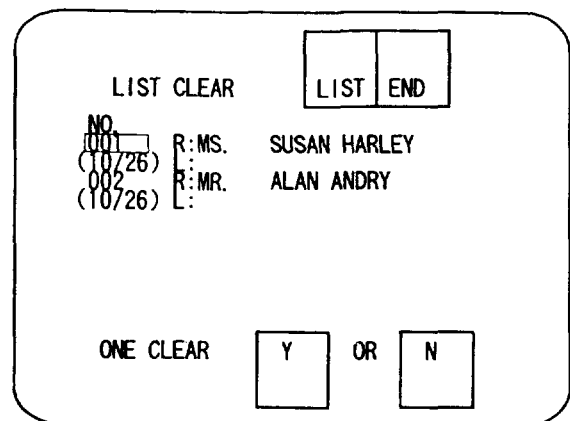

Figure 5-14 Y and N Keys

(3)-2 NO. & CLOCK SET Screen

The control No. and clock can be set as follows:

- ① Press the [NO.&CLK] key on the menu screen (see page 27 and Figure 5-6).

The NO. & CLOCK SET screen displays (see Figure 5-15).

- ② Press the [↓] key to move the cursor to the No. or CLOCK line you want to set.

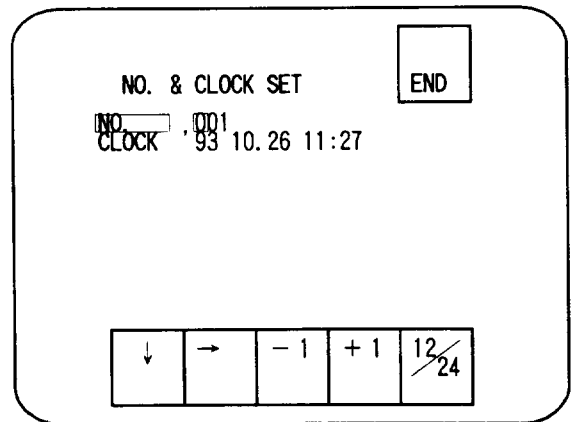

Figure 5-15 NO. & CLOCK SET Screen

1) To set the clock:

- ① Use the [→], [-1] and [+1] keys to set the clock.
- ② Use the [12/24] key to select either 12-hour or 24-hour display.

2) To set control No.:

Each time you press the [→] key, the cursor moves through the hundreds, tens and units. Position the cursor to area you want to change.

Press the [-1] key to decrement the number on the cursor by 1.

Press the [+1] key to increment the number on the cursor by 1.

To return to the measurement screen, press the [END] key.

1. Concerning the control No. setting:
 - The set number can be used as the number of the next measurement.
 - An existing control No. can be set if it is associated with a different date of measurement.
2. If an impossible time (for example, 26:72) is entered, pressing the [END] key will not return to the measurement screen. Reenter a correct time.

(3)-3 Message Entry Screen

(Useful information such as a hospital name or telephone number can be entered and included in the printouts. Up to 3 lines of 22 characters can be entered.)

- ① Press the **MSG** key on the menu screen (see page 27 and Figure 5-6).

The message entry screen appears (see Figure 5-16).

- ② You can enter a message in the same method as in the name entry screen (see pages 25 and 26).

To return to the measurement screen, press the **[END]** key.

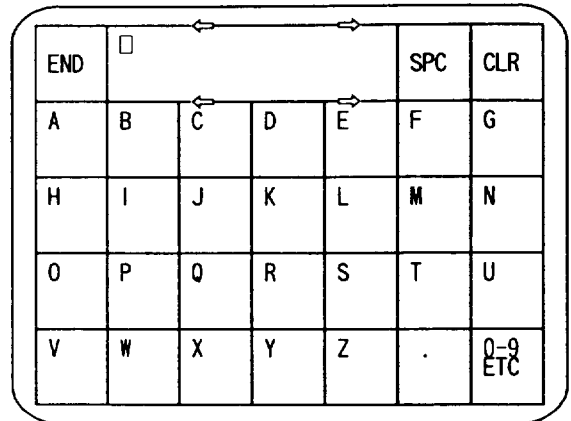

Figure 5-16 Message Entry Screen (A-Z)

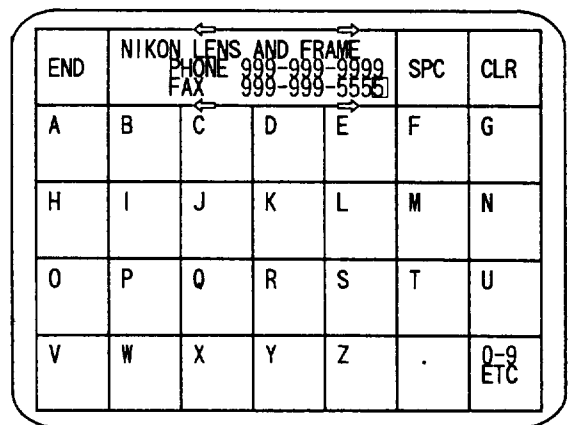

Figure 5-17 Message Entry Screen (After a Message is Entered)

The entered messages cannot be printed out unless MESSAGE is set to ON in the SYSTEM DATA SET screen (see page 37).

(3)-4 SYSTEM DATA SET Screen

This screen can be used to set the system configuration.

- ① Press the [SYS
SET] key on the menu screen (see page 27 and Figure 5-6).

The SYSTEM DATA SET screen appears (see Figure 5-18).

- ② Press the [↑] or [↓] key to move the cursor to a field you want to set.

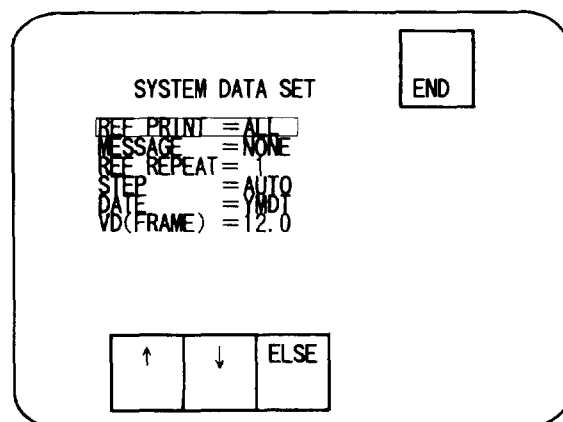

Figure 5-18 SYSTEM DATA SET Screen

- ③ Press the [ELSE] key to select your desired option.

Option	Description
REF PRINT = ALL REP NONE	Prints out the refraction measurement data and the representative values (up to 20 items for one eye). Prints out only the representative values of the refraction measurement. Does not print out the refraction measurement data. Data is not stored unless you press the PRINT switch.
MESSAGE = NONE ON	Does not print out a message. Prints out a message entered on the message entry screen (see page 36).
REF REPEAT = 1 10	Repeats the refraction measurement by the specified number of times (1-10) (see page 12).
STEP = AUTO 0.12 0.25	Controls the unit of SPH and CYL values as follows: Within $\pm 3D$: 0.12D Above $\pm 3D$: 0.25D Sets uniformly the unit of SPH and CYL values to 0.12D. Sets uniformly the unit of SPH and CYL values to 0.25D.
DATE = YMDT DMYT MDYT	Year, Month, Date, Time display Date, Month, Year, Time display Month, Date, Year, Time display
VD (FRAME) = 12.0 13.5 13.8 15.0 ALL	VD can be set to either 0.0, 12.0 VD can be set to either 0.0, 13.5 VD can be set to either 0.0, 13.8 VD can be set to either 0.0, 15.0 VD can be set to either 0.0, 12.0, 13.5, 13.8, 15.0

To return to the measurement screen, press the [END] key.

(3)-5 Automatic Fogging Cancel Screen

Use this screen to cancel the automatic fogging mechanism operation (see pages 12 and 14).

When the auto fogging is canceled, faster measurement of unsteady eyes such as children or older persons is possible although their eyes could possibly accommodate.

Press the $\begin{matrix} \text{NORM} \\ \text{FOG} \end{matrix}$ key on the menu screen (see page 27 and Figure 5-6) so that the $\begin{matrix} \text{NORM} \\ \text{FOG} \end{matrix}$ key display will change into $\begin{matrix} \text{FAST} \\ \text{FOG} \end{matrix}$ (Figure 5-19) to cancel the automatic fogging mechanism operation.

Return to the measurement screen.

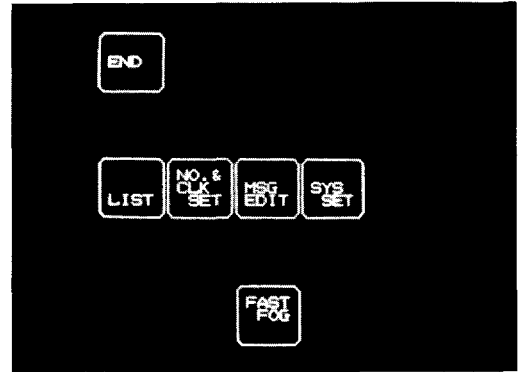



Figure 5-19

6. *Automatic Power Saving*

- When a key-in is not made for about 4.5 or 5 minutes after you are in the measurement screen, the instrument automatically enters a power saving mode.
- In this mode, the screen goes dark but the POWER lamp remains on.
- Press the [PRINT] switch or start button  to restore the instrument to the previous screen immediately before it entered the power saving mode.
- Measured values or representative values are retained during the power saving mode.

7. Maintenance

(1) Replacing a Paper Roll

Turn ON the instrument and open the measurement screen.

- (1) When the print paper comes close to its end, a red line will appear on the paper. It is now time to replace the paper roll.

Pull down the lever and remove the paper roll (see Figure 7-1).

Raise the lever.

- (2) Remove the securing tape from the new paper roll (see Figure 7-2).

- (3) Pull out the paper one revolution of the roll and fold it (see Figure 7-3).

Gently cut the paper along the crease (see Figure 7-4).

(The purposes of this process is to avoid printing on the remaining adhesive after the securing tape has been removed, and to make the paper roll easier to insert into the paper inlet.)

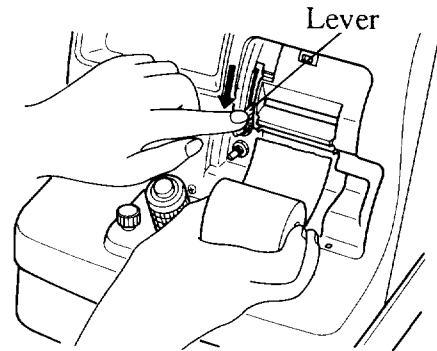

Figure 7-1

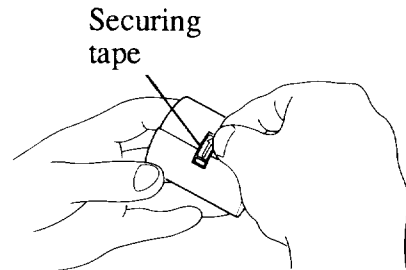

Figure 7-2

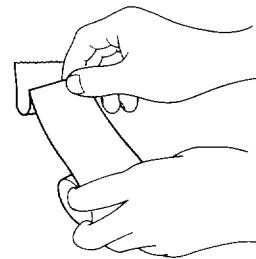

Figure 7-3

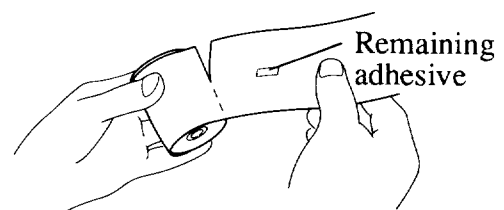

Figure 7-4

- (4) While the measurement screen is displayed press the [PRINT] switch (see Figure 7-5).

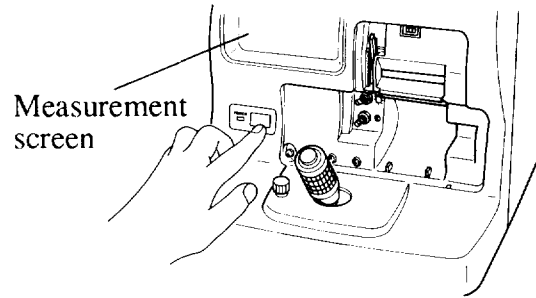

Figure 7-5

The message "PAPER END" will appear near the center of the screen. While this message is displayed, insert the leading edge of the paper into the paper inlet (see Figures 7-6 and 7-7).

The paper is automatically fed.

(If the paper is not fed, further push the leading edge of the paper into the paper inlet and press the [PRINT] switch again.)

This slot is not the paper inlet.

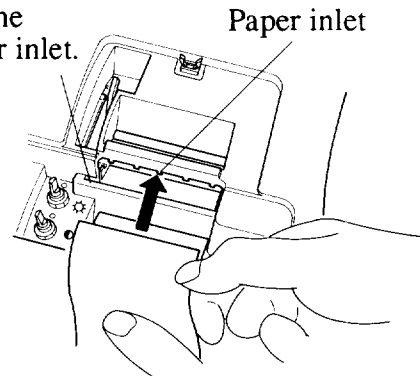

Figure 7-6

In the following situation, hold down the lever and position the paper, then raise the lever.

- Paper is difficult to insert.
- Paper was fed skewed.

- (5) Reattach the printer cover.

Do not insert the paper upside down, as it will not print (thermal paper prints on one side only).

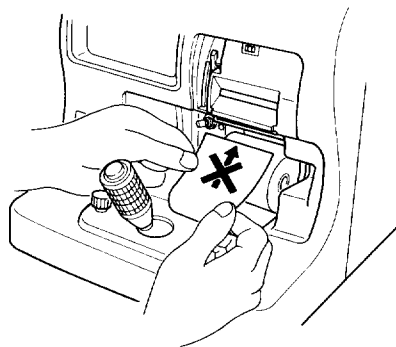

Figure 7-8

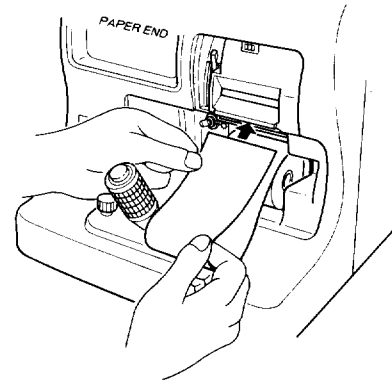

Figure 7-7

If the print paper ends during printing, the message PAPER END appears on the screen. Install a new paper roll as shown in Figures 7-7 to resume printing. (During the PAPER END state, do not turn OFF the instrument.)

(2) Changing the Fuses

After turning on the power switch, if the power lamp, patient target and screen do not illuminate, the fuses may have blown.

To check the fuses, first turn OFF the power switch and disconnect the power cord from the main outlet.

Hold the tabs on both the sides of the fuse holder with a small flat-top screwdriver and pull it out. Remove the two fuses from the fuse holder and check to see if they have blown. If so, replace the fuses.

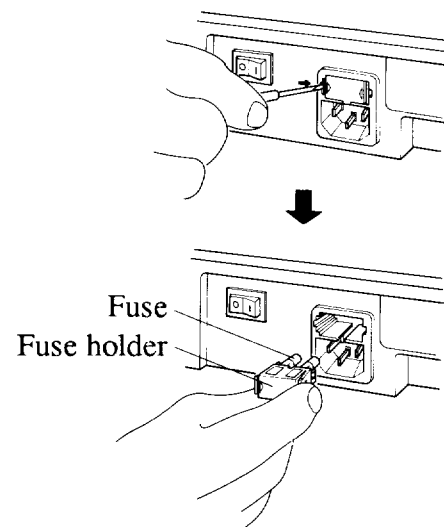

Figure 7-9

Use the recommended fuses only:

Please place an order with your local Nikon distributor for spare replacement fuses.

For A.C. 100V/120V area

Time-delay fuse 125V 4A

(type NAGASAWA ELECTRIC WORKS, LTD. "SB4" $\phi 5.2 \times 20\text{mm}$)

For A.C. 230V area

Time-delay fuse 250V 2A

(type NAGASAWA ELECTRIC WORKS, LTD. "ES3-2000" $\phi 5.2 \times 20\text{mm}$)

(3) Cleaning the Chin and Forehead Rests

Periodically wipe them with a soft cloth or tissue paper moistened with alcohol or lens cleaning liquid over the surfaces of the chin and forehead rests.

(4) Cleaning the Measuring Window

The measuring window is dust-resistant glass. If any dust on the glass is visible from the patient side, use the blower provided to powerfully blow air several times to remove the dust. If the dust cannot be removed, wipe the lens with a cleaning liquid or alcohol. Because the dust-resistant glass is thin and fragile, do not press it too hard!

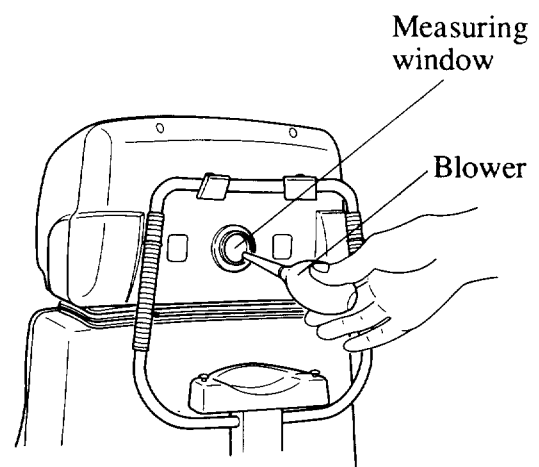

Figure 7-10

(5) Cleaning the Touch Panel

Turn the instrument OFF.

Wipe with a silicon cloth or a cloth moistened with a mild detergent over the touch panel. Do not use an organic solvent such as alcohol.

(6) Model Eye

When correct measured values cannot be obtained with the model eye, its lens surface could possibly be contaminated by dust or a finger print. Gently wipe it with a soft and well-washed cotton cloth (such as gauze) moistened with a little cleaning solution or alcohol over the lens surface being careful not to scratch it. (Never use a handkerchief or degreased cotton wool.)

A microscopic scratch on the lens surface of the model eye may reduce the accuracy of measurement. Be careful not to bump the model eye against a hard object or drop it on the floor as this may damage it.

(7) Error Indication

When the power switch is turned on, normally the message POWER ON CHECKING will appear on the screen. If the instrument has internal trouble at this time, ERROR and a two-digit error number will be displayed for a few seconds before the measurement screen appears.

If ERROR and a two-digit error number are displayed, turn off the instrument and then turn it on again. If the two-digit number reappears again, contact your local Nikon service staff and inform them of the two-digit number indicated, because this number shows a malfunction is occurring in the instrument.

8. *Connecting with an External Device*

This instrument has an interface connector complying with EIA RS- 232C at the side of the base.

This connector can be used to send measured values to an external device such as Nikon Auto Optester and a personal computer.

If the NR-5500 is connected with the Nikon Auto Optester (such as the OT-3A, OT-7A or OT-8A) the objective measurement data may be automatically loaded into the Optester for a faster and more efficient subjective examination.

If you create and run an appropriate software program on your personal computer, the recording and statistical processing of data sent from NR-5500 will be done more efficiently.

For further information concerning the interface connection, contact a Nikon distributor.

9. Specifications

Refraction measurement

Measurement range

Spherical power:	-18.00D ~ +23.00D
Cylindrical power:	-12.00D ~ +12.00D
Cylindrical axis:	1° ~ 180°
(-18D < spherical power + cylindrical power < +23D)	
Pupil distance:	85 mm or less

Minimum unit

Spherical power:	0.12D or 0.25D
Cylindrical power:	0.12D or 0.25D
Cylindrical axis:	1°
Pupil distance:	1 mm

Corneal vertex distance: Selectable from 0, 12, 13.5, 13.75 (displayed as 13.8), 15 mm

Minimum pupil diameter: 2.9 mm

Measurement time: 0.17 sec. (fogging 0.9 sec.)

Target: Picture slide target

Memory capacity: Data for 300 patients

Measurement mode: Refractometer
Ref continuous (By holding down the joystick button.
Number of repetitions can be selected between 1
and 10.)

Abbreviated fast fogging mode: Possible (for children, etc.)

Fixation chart brightness control: 3 levels

IOL patient measurement: Without switch changeover

Enhanced retro illumination setting: Dynamic image

Eyeball printing: Standard

Main Body

Switch;	Touch-sensor screen and print key
Joystick:	Ommi-directional
Alignment index:	Blue ring on chinrest/Table marks
Input supply voltage:	AC100V~120V or AC230V, 50/60 Hz
Power consumption:	92VA max.
Fuse capacity:	AC100V~120V area: T4A AC230V area: T2A
CRT monitor:	5-inch black and white monitor
Real-time clock:	Present
Interface:	RS-232C
Power saving system:	Blacks out the screen when no key-in or measurement is made for 4.5 or 5 minutes.
Printer:	Thermal line printing type, paper width of 60 mm (NL-30 paper usable)

Dimensions: 330 (w) × 505 (h) × 475 (d) mm

Weight: About 22 kg

Option: IC card reader/writer

10. Equipment Supplied

- NR-5500
- Power cord
- Cord retainer
- Vinyl cover
- Print paper rolls (5)
- Blower
- Model eye
- Spare fuses (2)
- Phillips screwdriver
- Instructions manual