

HUMPHREY®

FDT Visual Field Instrument



USER'S GUIDE



Humphrey
SYSTEMS

WelchAllyn™

**FREQUENCY DOUBLING
TECHNOLOGY**

ZEISS HUMPHREY SYSTEMS • 5160 HACIENDA DRIVE, DUBLIN, CALIFORNIA, USA 94568 • 877-486-7473
E-MAIL: INFO@HUMPHREY.COM • WEB: HTTP://WWW.HUMPHREY.COM

PRINTED IN U.S.A.

Part No. 112098-1 Rev. D

TABLE OF CONTENTS

1 PLEASE READ

IMPORTANT SAFETY INFORMATION	1
------------------------------------	---

2 INTRODUCTION

ABOUT THE USER'S GUIDE	3
INSTRUMENT OVERVIEW	3
INSTRUMENT COMPONENTS	5
FDT OVERVIEW	5

3 OPERATING PROCEDURES

UNPACKING	7
PREPARATION FOR USE AND POWER ON	8
PREPARING FOR A PATIENT TEST	11
RUNNING A SCREENING OR THRESHOLD PATIENT TEST	14
DISPLAYING & PRINTING THE TEST RESULTS	17
USING THE RS-232 SERIAL COMPUTER INTERFACE	18
UNDERSTANDING THE SCREENING TEST RESULTS	18
UNDERSTANDING THE FULL THRESHOLD TEST RESULTS	19
SCREENING C-20 TEST RESULTS SAMPLE	22
THRESHOLD C-20 TEST RESULTS SAMPLE	23
THRESHOLD N-30 TEST RESULTS SAMPLE	24

4 CALIBRATION AND SET-UP, MAINTENANCE AND TROUBLESHOOTING

CALIBRATION AND SET-UP	25
Set Date and Time	25
Set-up Instrument Options	26
Calibration	27
Software Upgrade	28
MAINTENANCE	28
Printer Paper Replacement	28
Replacement Parts and Accessories	30
Product Model Numbers (710 SERIES)	30
Cleaning, Disinfection and Sterilization	31
TROUBLESHOOTING	31

5 WARRANTY AND SERVICE INFORMATION

WARRANTY INFORMATION	33
SERVICE INFORMATION	33
Technical Assistance Information	33

6 TECHNICAL SPECIFICATIONS

INSTRUMENT SPECIFICATIONS	35
ENVIRONMENTAL SPECIFICATIONS	35
TEST SPECIFICATIONS	36
STANDARDS COMPLIANCE	37

FDT QUICK REFERENCE GUIDE

**IMPORTANT SAFETY INFORMATION**

All operating personnel should be familiarized with the general safety information in this summary. Additional safety information may also be found throughout this manual.

⚠ ATTENTION - refer to the operating instructions. This symbol ⚠ is intended to alert the operating personnel to the presence of important operating or maintenance instructions in the documents accompanying the instrument.

⚠ OPERATING VOLTAGE SELECTION - select the desired operating voltage range, either 115V or 230V, before connecting the power cord to the appliance inlet connection and before applying power to the instrument. Be sure the proper fuse values are used for each voltage setting. Refer to the Preparation for Use and Power On section of this manual for instructions to change the Voltage Selector position.

⚠ FUSE REPLACEMENT- For the **115V** voltage selector position, replace the fuses with TYPE **T .315A 250V**. For the **230V** Voltage Selector position, replace the fuses with TYPE **T .160A 250V**. Refer to the Preparation for Use and Power On section of this manual for instructions to inspect or change the fuses.

⚠ SERVICE or REPAIR to be performed by QUALIFIED, AUTHORIZED PERSONNEL ONLY. There are **NO USER SERVICEABLE PARTS INSIDE** the instrument. Disassembly of the instrument beyond the extent required to change the **PRINTER PAPER, FUSES, or PATIENT RESPONSE BUTTON** as described in this manual presents a possible **ELECTRICAL SHOCK** hazard and will **VOID** the warranty.

⚠ REPLACEMENT PARTS and ACCESSORIES- Use only approved replacement parts and accessories specified in this manual. Refer to the maintenance section of this manual for more information.

⚠ MAINS DISCONNECT- Disconnect from the mains via the appliance inlet.

⚠ POWER CORD- Use an approved hospital-grade power inlet cord only.

⚠ DO NOT STERILIZE the instrument or any of its components.

⚠ After unpacking the instrument, pull down the printer door (below the LCD display), using the finger cutouts on the sides of the door (near the top), and **remove the foam shipping wedge BEFORE using the printer.** Close the printer door. Be sure the paper is sticking out through the slot in the door. **Failure to remove the shipping wedge will result in improper operation of the printer.**

⚠ DO NOT USE the instrument near other equipment which produces strong magnetic fields (such as MRI). The video monitor performance may be adversely affected.



LCD DISPLAY CONTRAST - Use the UP and DOWN arrows adjacent to the contrast symbol below the LCD display to adjust the LCD contrast for optimum viewing, based on lighting conditions.



TYPE BF - Indicates this is a Type B product with Type BF applied parts; the patient forehead rest and patient response Button.



SHIPPING and STORAGE TEMPERATURE range - Limit the temperatures the instrument is exposed to between **-20° C (-4° F) and +49° C (+120° F)** to avoid possible damage to the instrument. Refer to the environmental specifications section of the manual for more information.

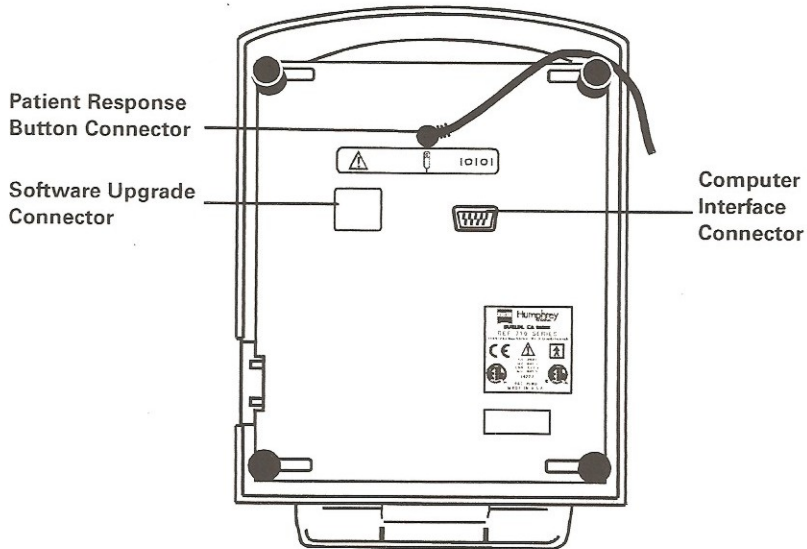

PATIENT RESPONSE BUTTON CONNECTOR - Connect **ONLY** the patient response button supplied with the instrument or an approved replacement to the patient response button connector on the bottom of the instrument. Connection of any other device to the patient response button connector may damage the instrument or create an unsafe condition and will void the warranty.



COMPUTER INTERFACE CONNECTOR - Connect **ONLY RS-232 serial compatible** computer ports to the computer interface connector on the bottom of the instrument. Use the null-modem configuration computer interface cable supplied with the instrument or an approved replacement cable. Connection of any other computer port or device to the computer interface connector may damage the instrument. Refer to the computer interface instructions for additional information.



SOFTWARE UPGRADE CONNECTOR - The blank label on the bottom of the unit adjacent to this symbol covers the SOFTWARE UPGRADE CONNECTOR. The blank label should only be removed during a software upgrade and should be replaced when the upgrade is complete. Refer to the software upgrade instructions to update the instrument software.

ABOUT THE USER'S GUIDE

The USER'S GUIDE is designed to help you understand the capabilities and operation of the Humphrey FDT Visual Field Instrument with Welch Allyn's FREQUENCY DOUBLING TECHNOLOGY. To achieve satisfactory results, the operator should read this manual thoroughly before using the instrument. An FDT Quick Reference Guide is provided for the convenience of experienced operators.



INSTRUMENT OVERVIEW

The FDT Visual Field Instrument is an innovative, efficient, compact and affordable automated visual field testing instrument. Years of research and clinical trials of Welch Allyn's patented FREQUENCY DOUBLING TECHNOLOGY have resulted in an instrument which provides rapid, clinically validated and user-friendly visual field testing.

Key features of the FDT Visual Field Instrument include:

- Supra-threshold screening tests in less than 1 minute per eye
- Full-threshold tests in approximately 4 minutes per eye
- Easy to use; no special training is needed/minimal operator instruction
- No corrective (trial) lens needed; patients can wear their own correction or none at all (must only be within 7D of patient's refraction)
- No eye patch needed for the opposite (untested) eye - it's automatically occluded
- Not affected by ambient lighting - can be used in normal room lighting
- Not affected by pupil size (as small as 2 mm)
- Extensive age-normative reference database incorporated
- World-class clinical validation by leading researchers in the field
- Statistically significant correlation to the Humphrey Field Analyzer
- Software upgrade capability for future enhancements

PATIENT'S SIDE INSTRUMENT COMPONENTS

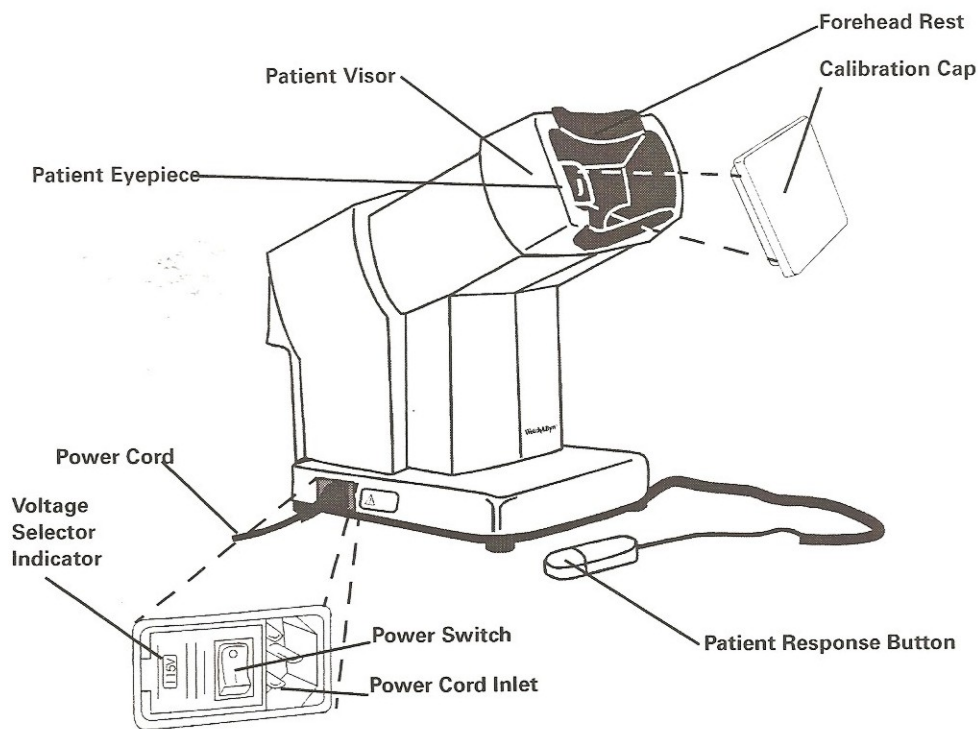

OPERATOR'S SIDE INSTRUMENT COMPONENTS

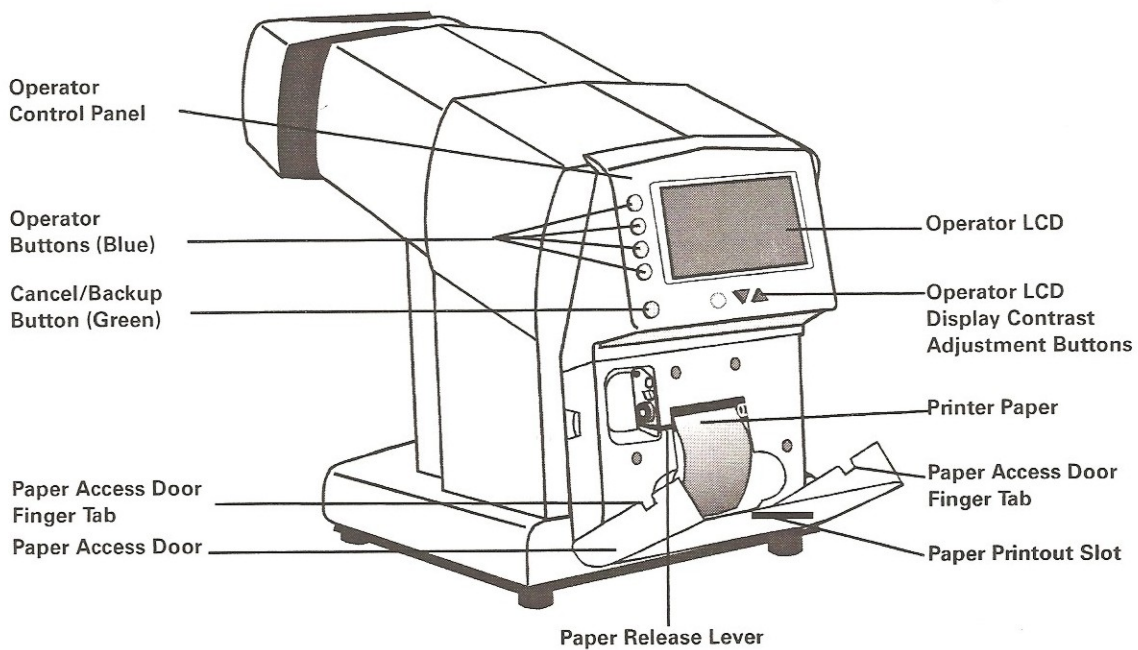

INSTRUMENT COMPONENTS

The instrument has seven Buttons to control the operation of the instrument, located adjacent to the Operator's Liquid Crystal Display (LCD).

- Four BLUE Operator Buttons along the left side of the Operator LCD Display
- A GREEN Cancel/Backup Button below the four BLUE Buttons
- Two Operator LCD Display Contrast Adjustment Buttons (Down Arrow and Up Arrow) adjacent to the Contrast Symbol and directly below the LCD Operator Display

Further below the Operator LCD Display is a Paper Access Door which opens to provide access to the internal thermal printer for replacement of paper, when needed. The instrument has a sliding Patient Visor which aids in the selection of the eye to be tested and automatically occludes the opposite (untested) eye. Detachable Patient Response Button, Power Cord, and Calibration Cap are also provided.

FDT OVERVIEW

FDT isolates a subset of retinal ganglion cell mechanisms in the magnocellular (M-cell) pathway. These M-cells have large diameter fibers and comprise only 3% to 5% of all retinal ganglion cells. The damage of these cells in the disease process makes FDT efficient and effective for the detection of visual field loss.

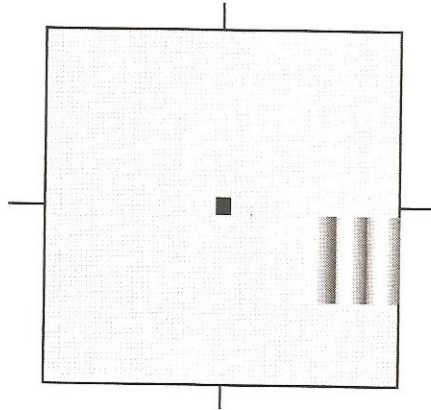

PATIENT'S VIDEO
SCREEN PATTERNS

INTRODUCTION

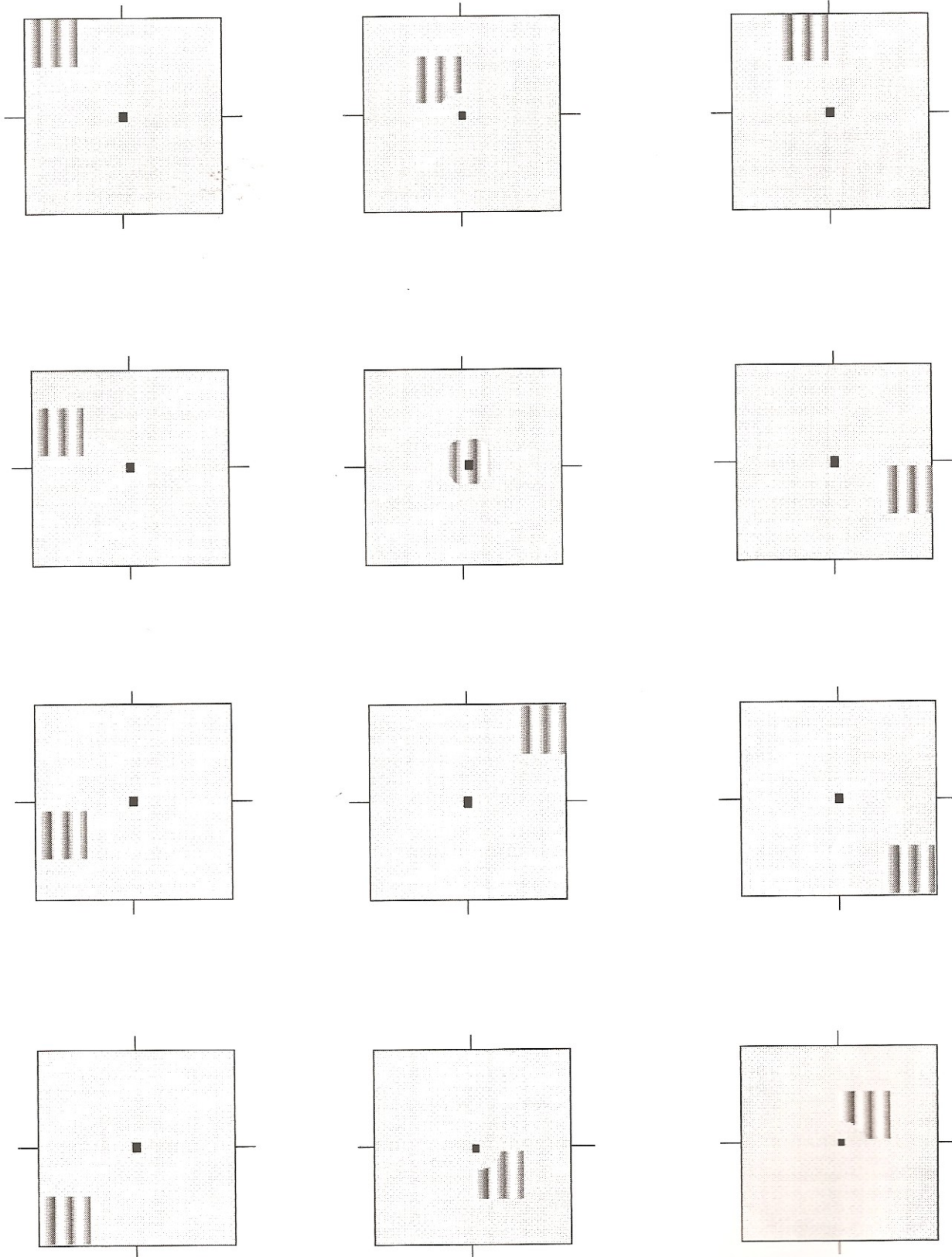

UNPACKING

This instrument is designed for use by anyone familiar with the operation as described in this manual; no special qualifications are required. Anyone using this instrument should read and understand the operating instructions manual before using the instrument. Interpretation of the results should be performed only by appropriately trained eyecare professionals.

Open the shipping box by carefully cutting the packing tape securing the top flaps of the box. Lift out the foam insert containing the Patient Response Button, Power Cord and extra roll of paper. Lift the instrument out of the remaining foam insert by grasping the instrument at the two cutouts provided and set the instrument on a flat, stable surface. Remove the plastic bag from the FDT Visual Field Instrument. Use of an adjustable height chair and/or table is recommended when performing testing.

After you have unpacked the instrument and its components, confirm that you have received the following items in good condition:

- Humphrey FDT Visual Field Instrument
- Calibration Cap (covering the Patient's Eyepiece inside the Patient Visor)
- Patient Response Button
- Power Cord (appropriate for local operating voltage)
- Extra roll of paper

RETAIN THE SHIPPING MATERIALS (BOX AND PACKAGING) IN THE EVENT OF SHIPPING DAMAGE OR FOR RETURN, IF NECESSARY, TO AN AUTHORIZED SERVICE OR DISTRIBUTION LOCATION AT ANY TIME IN THE FUTURE.

⚠ After unpacking the instrument, pull down the Paper Access Door (below the LCD display) using the Finger Tabs on the sides of the door. Remove the foam shipping wedge *before* using the printer. Close the Paper Access door while guiding Printer Paper through the Paper Slot in the door. Failure to remove the shipping wedge will result in improper operation of the printer.

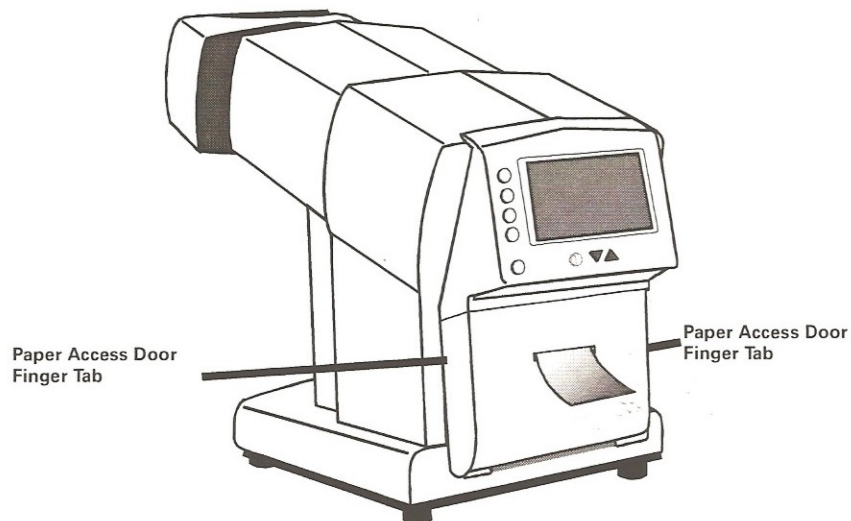

PREPARATION FOR USE AND POWER ON

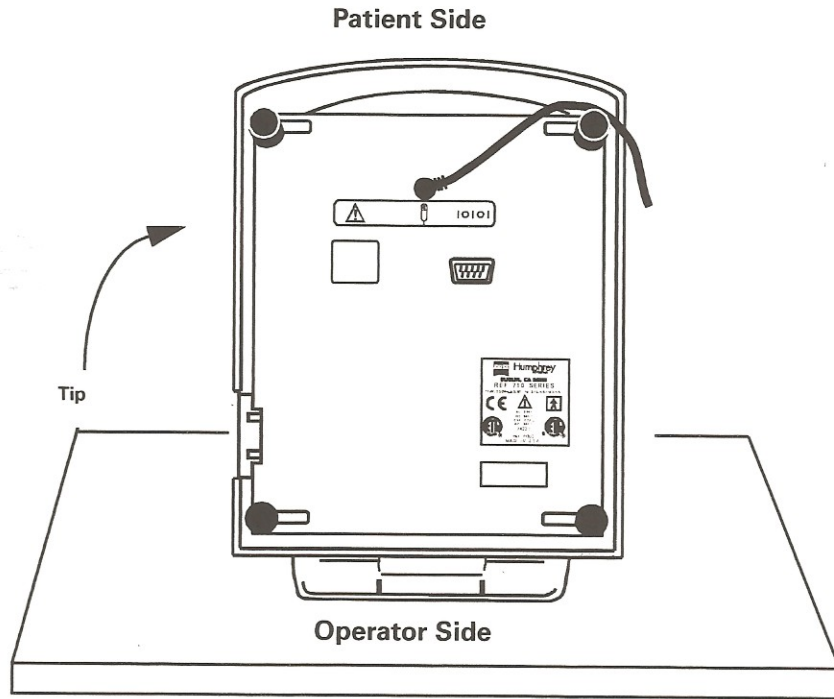

While facing the Patient Side of the FDT instrument, tilt the instrument to plug the **Patient Response Button** connector into the small round connector jack. The jack is located underneath the base of the unit (at the center) and near the patient response button symbol .

⚠ OPERATING VOLTAGE SELECTION - select the desired operating voltage range, either 115V or 230V, before connecting the power cord to the appliance inlet connection and before applying power to the instrument. Be sure the proper fuse values are used for each voltage setting.

Before connecting the Power Cord and **before** applying power to the instrument, be sure the **Voltage Selector Indicator** adjacent to the **O/I Power Switch** displays the appropriate operating voltage (115V or 230V).

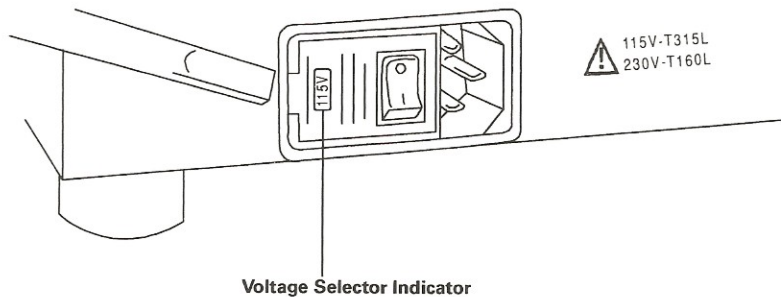

To change the Fuse Carrier/Voltage Selector to the proper operating voltage be sure the Power Cord is NOT connected and use a flat screwdriver to pry open the Fuse Drawer Cover. Remove the

Fuse Carrier/Voltage Selector, by again using a flat screwdriver, noting the placement of the fuses before removing them. Remove and replace **both** fuses, by carefully prying them out and replacing them with the value indicated on the fuse replacement label (for 115V use TYPE **T .315A 250V** fuse and for **230V** fuse TYPE **T .160A 250V** fuse). Rotate the Fuse Carrier/Voltage Selector so the proper voltage will be visible when the Voltage Selection Door is closed. Re-install the Fuse Carrier. Close the Fuse Drawer Cover and check to be sure the proper voltage appears in the Voltage Selection Window. Refer to the Replacement Parts and Accessories section of this manual for fuse part numbers and ordering information.

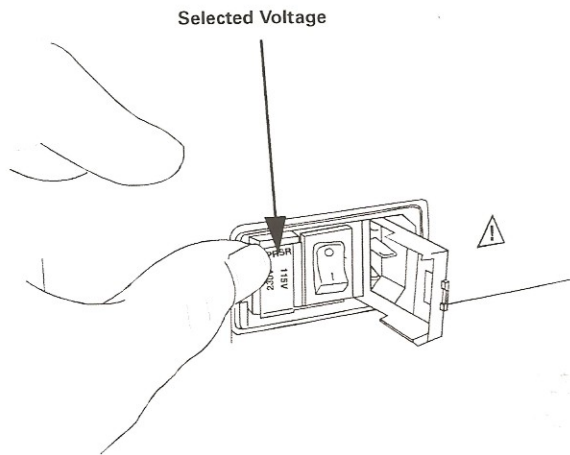
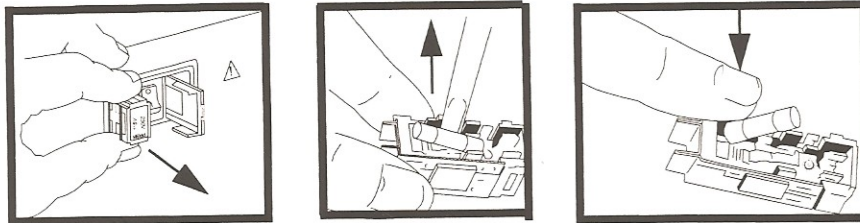
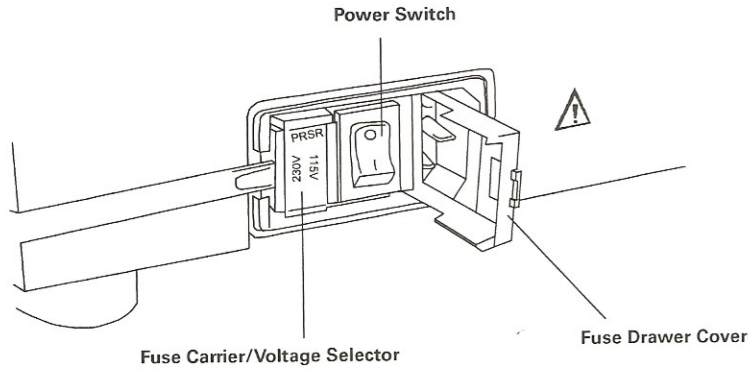

Plug the appropriate approved hospital grade detachable Power Cord into the Power Cord Inlet on the operator's right-hand side and plug the opposite end into a standard power outlet.

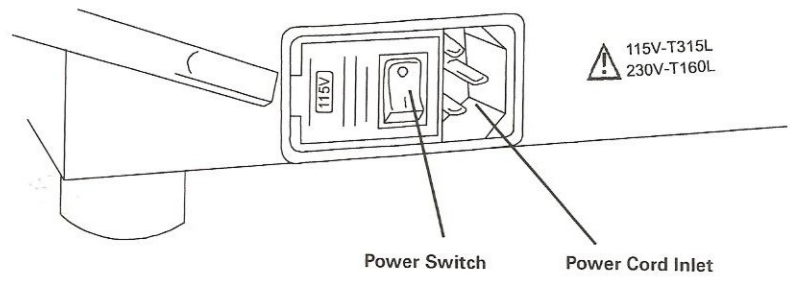

To turn the instrument ON, switch the **Power Switch (O/I)**, adjacent to the power connector, to the **ON (I) position**. The instrument will perform internal self-diagnostic checks and after approximately 15 seconds, two double beeps will sound and the **FDT MAIN MENU** will appear on the Operator LCD Display. Refer to the troubleshooting section of this manual if the **FDT MAIN MENU** does not appear.

Note: You may need to adjust the **LCD contrast** in order to read the Operator LCD Display; use the triangle shaped buttons below the Operator LCD Display to increase (up-arrow) or decrease (down-arrow) the LCD contrast.

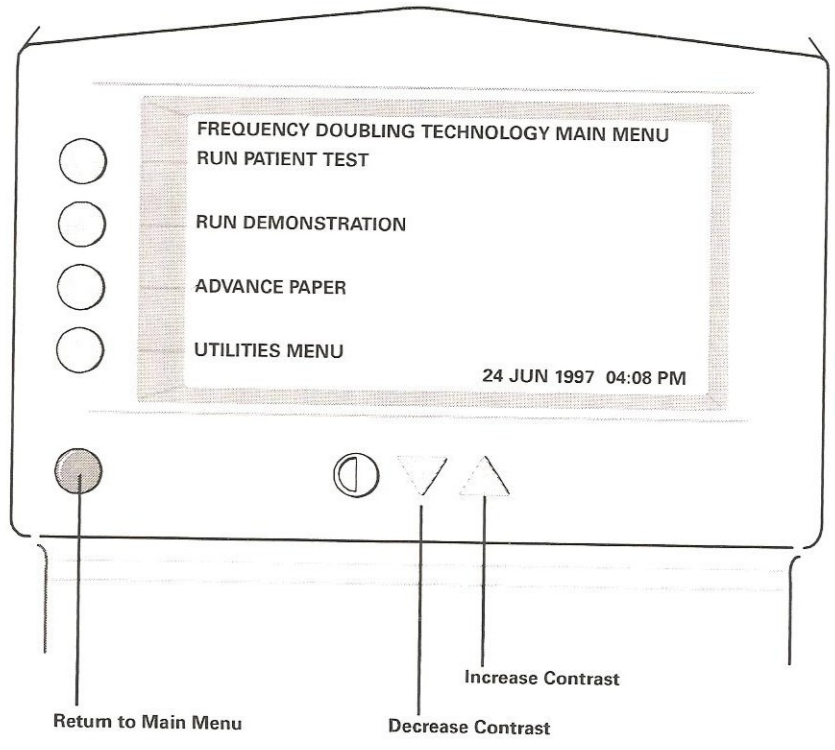

Note: the **GREEN Button** may be used at any time to back-up to the previous menu and to return to the **FDT MAIN MENU** (it may need to be pressed several times to reach the **FDT MAIN MENU**).

PREPARING FOR A PATIENT TEST

Remove the CALIBRATION CAP from the Patient Eyepiece. Replace the calibration cap on the Patient Eyepiece when the instrument is not in use to minimize the accumulation of dust and debris in the Patient Eyepiece.

Select **RUN PATIENT TESTS** from the **FDT MAIN MENU** to prepare for a **SCREENING C-20 TEST**, **FULL THRESHOLD C-20 TEST** or a **FULL THRESHOLD N-30 TEST**.

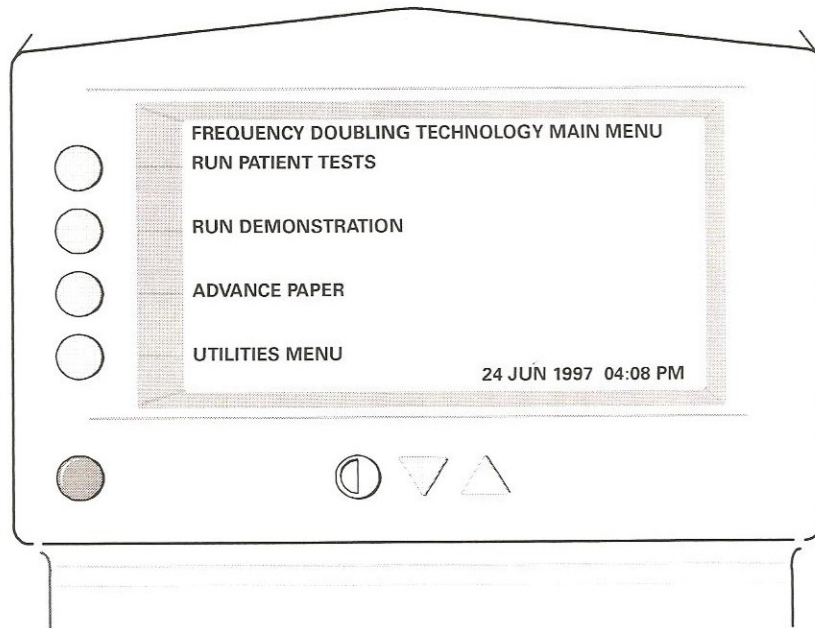

OPERATING PROCEDURES

Note: Once **RUN PATIENT TESTS** is selected, typical FDT stimulus presentations are automatically displayed to demonstrate the test to the patient until the test actually starts.

Enter the Patient's Age

The unit will start with an **AGE** of 50 years. Select **+10 YEARS (TOP BLUE Button)** to increase the **AGE** by 10 year increments (e.g. to 60, 70, and so on). Select **-10 YEARS (2nd BLUE Button from the top)** to decrease the **AGE** by 10 year increments. Select **+1 YEAR (3rd BLUE Button from the top)** to increase the **AGE** in 1 year increments to adjust to the **exact age of the patient** (e.g. 51, 52, and so on). Select **ACCEPT SETTING (BOTTOM BLUE Button)** when the **correct AGE** is displayed.

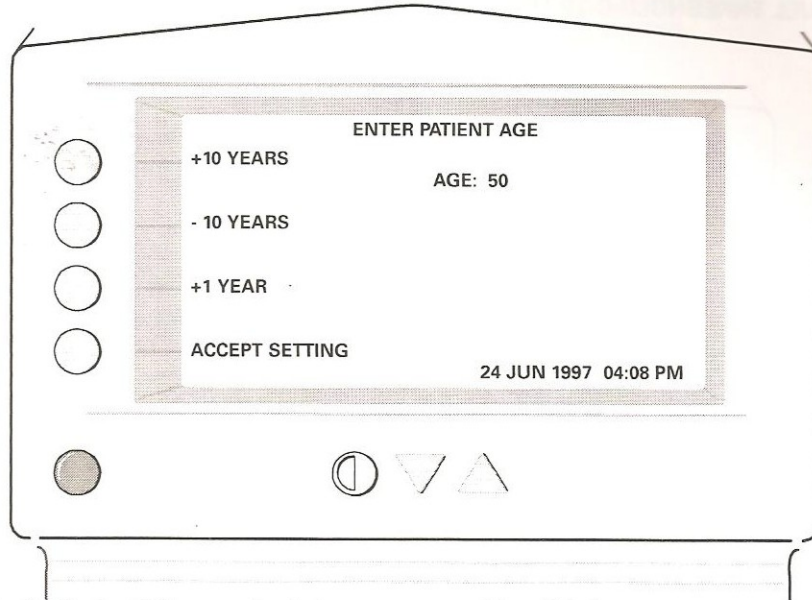

Slide the **Patient Visor** to the **right eye test position** (this is to your right when looking at the patient from the operator's side).

Note: If you want to **skip** the **right eye** (i.e., only test the left eye), then **slide** the **Patient Visor** to the **left eye test position** now (this is to your left when facing the patient from the operator's side) and select **SKIP RIGHT EYE**.

Prepare the Patient

Place the **Patient Response Button** in the patient's hand and show them how to press it. Ask the patient to place their forehead on the **Forehead Rest** and look into the **Patient Eyepiece at the video screen**. Adjust the **height** of the chair or table (or both) to obtain a comfortable position for the patient. Confirm that the patient can see the entire lit video screen, including all four corners, in the Patient Eyepiece and the black dot in the middle of the screen.

Note: Be sure the patient is positioned comfortably (not hunched over) by adjusting the height of the chair or table (or both).

Patient Refraction

The **FDT** test may be taken with or without the patient's correction (if the patient is within 7D of their refraction). If a patient is wearing glasses, confirm that their glasses frame does not obscure any of the lit portion of the display. Ask the patient to remove their glasses for the test if their lenses or contact lenses are tinted or change contrast based on lighting conditions (photochromatic). Tests may be taken with bifocal or progressive lenses (unless the progressive lenses have more than 3D equivalent sphere distance correction).

Explain the Test Procedure to the Patient

"A demonstration of the test is running now. Can you see the black dot in the center and the entire lit video screen? You need to stare at the black dot in the center of the screen during the entire test."

"From time to time, you will see patterns of **flickering black and white vertical bars** that will briefly appear in different areas of the screen. The patterns will **sometimes** be **very faint** and at other times be **very distinct**. You are not expected to see the bar patterns at all times. Each time you see the **flickering black and white vertical bars** of one of the patterns, **press the response button once**. Can you see these patterns in the demonstration running now? You may practice now by pressing the Button to respond to the patterns."

"It is OK to blink and a good time to blink is when you press the response Button. If you need to rest or ask questions during the test, you can pause the test at any time by pressing and holding down the response Button. Do you have any questions? Do you understand how to take the test?"

"I will now start the test. There will be a few brief flashes and then the test will begin. Press the response Button once each time you see the **flickering black and white vertical bars** of one of the patterns, even if the bars are very faint. Please remember to **stare at the black dot in the center of the screen** during the entire test."

Note: A separate **DEMONSTRATION** test is available from the **FDT MAIN MENU** to help facilitate the patient's understanding of the test, if needed. To run a practice test, select **RUN DEMONSTRATION (2nd BLUE Button from the top)** from the **FDT MAIN MENU**. A demonstration of the test stimulus automatically begins. The patient should use this time to become familiar with the test and practice using the **PATIENT RESPONSE BUTTON** (Ask the patient to look into the Patient Eyepiece within the Patient Visor and then test the procedure.) Press the **GREEN** Button to cancel the practice test and return to the **FDT MAIN MENU**.

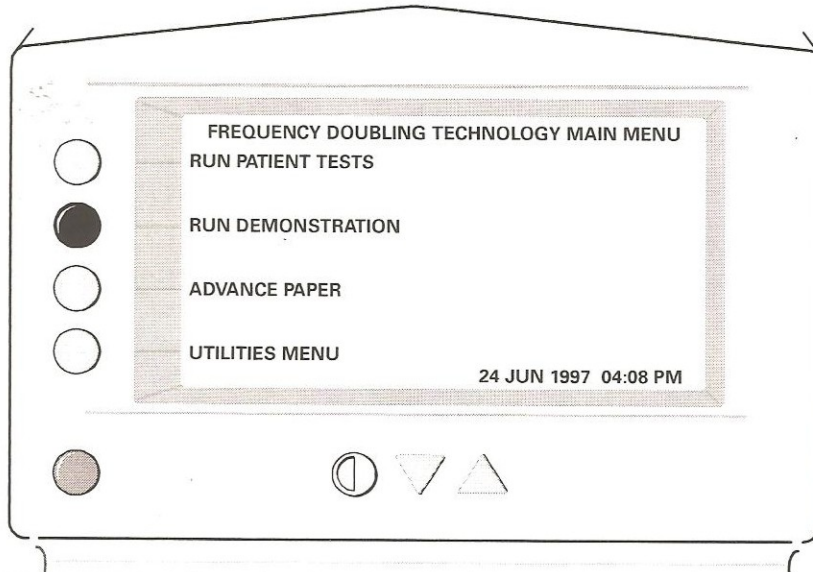

Be sure to prepare the patient as described above before running a practice test.

RUNNING A SCREENING OR THRESHOLD PATIENT TEST

Select either **RUN SCREENING TEST C-20**, **RUN FULL THRESHOLD C-20 TEST** or **RUN FULL THRESHOLD N-30 TEST** from the **RIGHT EYE TEST MENU**. The right eye test will begin **immediately** after a momentary check for proper calibration.

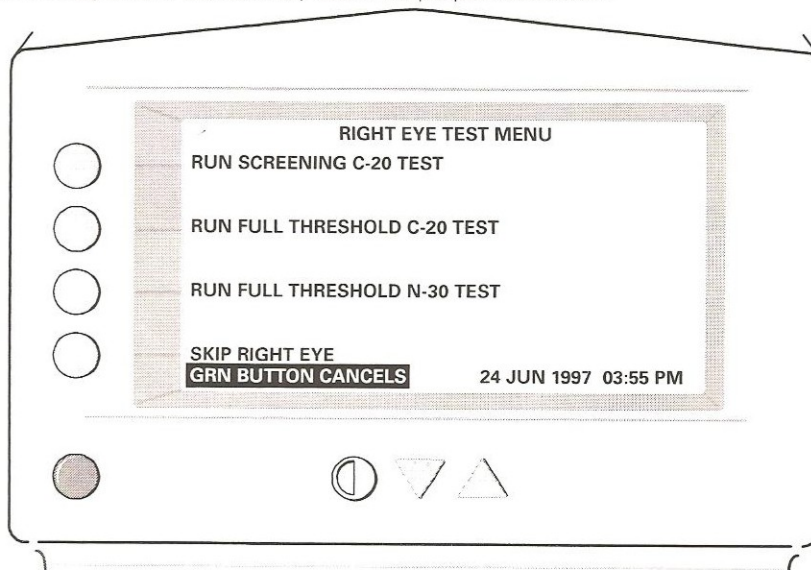

Note: To **skip** the **right eye** test and proceed directly to the left eye test, select **SKIP RIGHT EYE (BOTTOM Operator Button from the top)** **before** selecting a **SCREENING** or **THRESHOLD** test.
Note: The Operator LCD Display will indicate if there is too much ambient light to perform a reliable test. Lower the room lighting or change the test location until suitable test conditions are achieved.

Also, if the Patient Response Button is not connected or the Patient Visor is in the wrong eye position, this will be indicated on the Operator LCD Display.

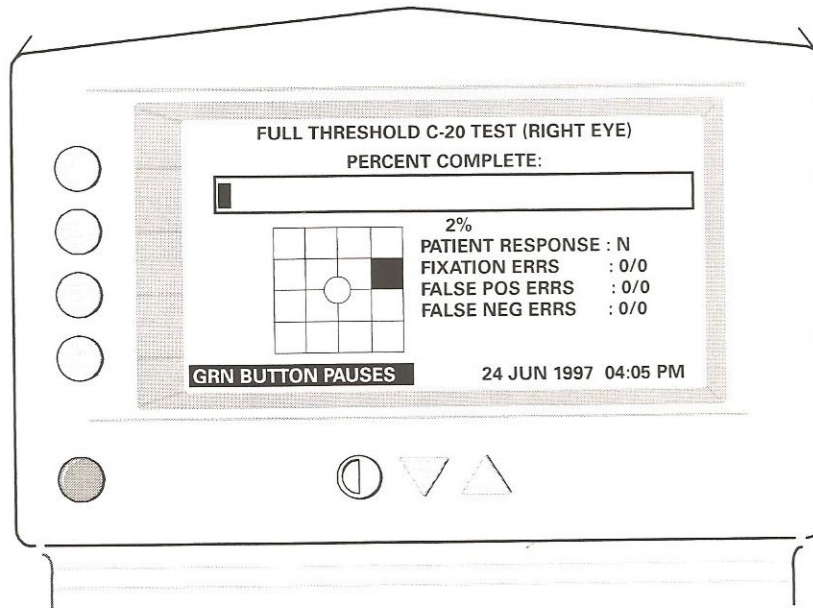

The **PERCENT COMPLETE** scale, field location being tested, **PATIENT RESPONSE**, **FIXATION ERRORS**, **FALSE POS ERRORS** and **FALSE NEG ERRORS** are displayed on the Operator LCD Display during the test. Remind the patient to keep looking at the dot in the middle of the screen and inform them of the approximate percent complete at 3 or 4 times during the test to encourage good patient compliance. Monitor the catch trials (**FIXATION ERRS**, **FALSE POS ERRS**, and **FALSE NEG ERRS**) during the test. The catch trial display fields will be highlighted on the Operator LCD Display if 2 or more catch trials have been responded to by the patient. A high ratio on any of the catch trials indicates unreliable results and that the test should be restarted or repeated.

Note: You can **PAUSE** or **RE-START** the test by pressing the **GREEN Button** at any time during the test. Follow the Operator LCD Display instructions to **CONTINUE TEST** or to **RE-START TEST** from a **pause**. The patient can also **PAUSE** the test (for a break, etc.) by simply pressing and holding down the **Patient Response Button**. The test will resume automatically once the patient releases the **Patient Response Button**. During patient pause, you may also select **OPERATOR PAUSE (GREEN Button)** so that the test will remain paused until you restart it.

Note: A **SCREENING C-20 TEST** takes less than **1 minute** (per eye) to complete, a **FULL THRESHOLD C-20 TEST** takes approximately **4 minutes** (per eye) to complete and a **FULL THRESHOLD N-30 TEST** takes about 4-1/2 minutes.

At the end of the right eye test, the Operator LCD Display will prompt for a left eye test. Slide the **Patient Visor** to the **left eye test position** (this is to your left when facing the patient from the operator's side). **Prepare the patient.** Select **RUN SCREENING C-20 TEST (TOP Operator Button)**, **RUN FULL THRESHOLD C-20 TEST (2nd Operator Button from the top)**, or **RUN FULL THRESHOLD N-30 TEST (3rd Operator Button from the top)** from the **LEFT EYE TEST MENU** to begin the left eye test *immediately* after a momentary check for proper calibration.



Note: To **skip** the **left eye** test, select **SKIP LEFT EYE (BOTTOM Operator Button)** to proceed to the results menu.

DISPLAYING & PRINTING THE TEST RESULTS

You can both view the results on the Operator LCD Display and print them out from the test results menu. At the end of a test, the results will be automatically printed (default set-up is automatic printing) and then the test results menu will automatically appear on the Operator LCD Display.

Select either **VIEW RIGHT EYE RESULTS (3rd Operator Button from the top)** or **VIEW LEFT EYE RESULTS (BOTTOM Operator Button)** to view the individual eye results for the patient just tested on the Operator LCD Display. Use the **GREEN Button** to back-up to the previous screen to allow you to toggle between the eye results or to return to the **FDT MAIN MENU** (press it twice if necessary). Select **PRINT REPORT (TOP Operator Button)** to obtain additional copies of the results for the patient just tested (you can print as many copies as you'd like).

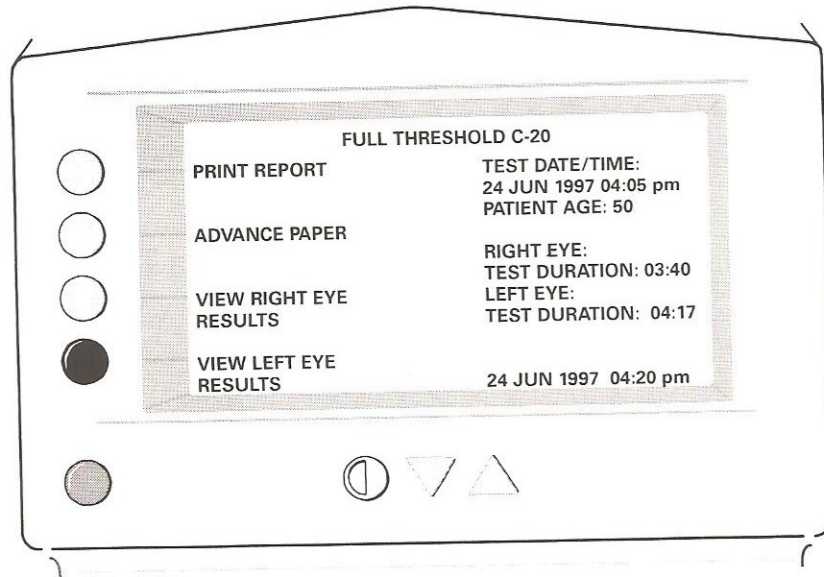

Note: Once the test is completed, you can also select **LAST PATIENT RESULTS (3rd Operator Button from the top)** from the **FDT MAIN MENU** to display or print out the results of the patient just tested. The results of the most recently tested patient will remain in memory *only until you begin a new test or until the instrument power is turned off.*

USING THE RS-232 SERIAL COMPUTER INTERFACE

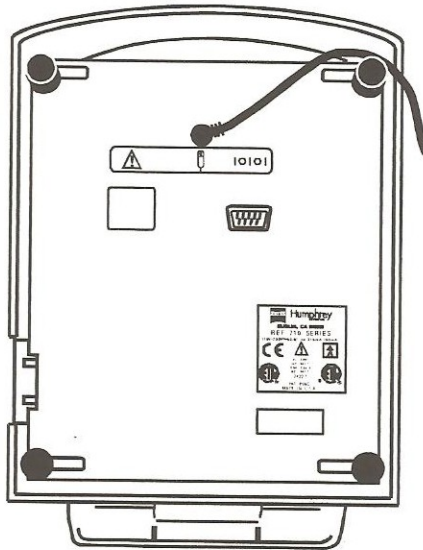

10101

The instrument includes an external serial RS-232 serial computer interface connector located on the bottom of the instrument. This interface provides the user with the ability to upload results from the instrument to a computer when the accessory computer interface cable and software are used. For detailed information on using the computer interface, reference the FDT PC operating instructions, available from authorized representatives.

UNDERSTANDING THE SCREENING C-20 TEST RESULTS

A plot of the 17 visual field locations tested will be printed (see samples on the following pages) and displayed on the Operator LCD Display for the supra-threshold **SCREENING C-20 TEST** for each eye tested. Each test location will be either *clear white* or will have *one of three possible levels of shading*.

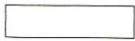

"WITHIN NORMAL LIMITS" - The patient *responded positively* (on either the first or second opportunity) when tested at the contrast level that **99% (P >= 1%)** of normal subjects of the same age would respond to for the test location with this shading.



"MILD RELATIVE LOSS" - The patient *failed to respond positively* when tested at the **1%** age normative contrast level (**P = 1%**) after being *given 2 opportunities* to do so (the instrument will re-test any point missed at the **1%** age normative level a second time) for the test location with this shading.



"MODERATE RELATIVE LOSS" - The patient *failed to respond positively* after being *given 3 opportunities* to do so; twice at the **1%** age normative contrast level (**P = 1%**) and a third time at the **0.5%** age normative contrast level (**P = 0.5%**) for the test location with this shading.



"SEVERE LOSS" - The patient *failed to respond positively* after being *given 4 opportunities* to do so for the test locations with this shading; the 3 opportunities listed above and a fourth at the **maximum** contrast level of the instrument.

When reviewing the results of the visual field test, careful consideration must be given to the **reliability indicators** (catch trials). The following two test reliability indicators appear on the printed report and Operator LCD Display for the screening test. They are an important measure of patient reliability in taking the test (and of the reliability of the results). They are indicated as a ratio of the number responded to the number presented. For example, **1/3** indicates that the patient responded to **1** of the **3** catch trials presented.

FIXATION ERRS : 0/3
FALSE POS ERRS : 0/3

FIXATION ERRORS - The ratio of the number of times the patient responded to a target placed in the blind spot versus the total number of times fixation was tested (i.e., total number of targets placed in the blind spot). Three **FIXATION catch trials** will be randomly presented for each eye. Fixation errors indicate the patient is not maintaining good fixation during the test, is misaligned, or does not understand the test.

FALSE POSITIVE ERRORS - The ratio of the number of times the patient responded to a "pause" in the testing sequence (i.e., no target presented) versus the total number of "pauses" in the testing sequence. Three **FALSE POSITIVE catch trials** will be randomly presented for each eye. False positive errors indicate the patient is pressing the Button even if the patient doesn't see any patterns or does not understand the test.

UNDERSTANDING THE FULL THRESHOLD C-20 AND N-30 TEST RESULTS

A plot of the 17 or 19 visual field locations tested will be printed (see samples on the following pages) and a combination plot will be displayed on the Operator LCD Display for the **FULL THRESHOLD C-20 and N-30 TEST** for each eye tested. The first printed results plot will contain a numerical contrast threshold level in units of **dB** for each location tested. The second printed results plot is a deviation plot and will be either *clear white* or will have *one of four possible levels of shading* corresponding age normative significance levels for each location tested. The results combination plot displayed on the Operator LCD Display will indicate both the numerical contrast threshold level and the shading for each location tested.

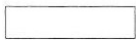

The patient achieved a threshold level in the range that **95% (P >= 5%)** of normal subjects of the same age achieved for the test locations with this shading.



The probability is less than **5% (P < 5%)** that a normal subject of the same age would perform at the threshold level that this patient achieved for the test locations with this shading.



The probability is less than **2% (P < 2%)** that a normal subject of the same age would perform at the threshold level that this patient achieved for the test locations with this shading.



The probability is less than **1% (P < 1%)** that a normal subject of the same age would perform at the threshold level that this patient achieved for the test locations with this shading.



The probability is less than **0.5% (P < 0.5%)** that a normal subject of the same age would perform at the threshold level that this patient achieved for the test locations with this shading. This shading will also occur if the patient **failed to respond** at the **maximum contrast level** of the instrument (**0 dB** will be indicated).

FIXATION ERRRS : 0/0
 FALSE POS ERRS : 0/0
 FALSE NEG ERRS : 0/0

When reviewing the results of the visual field test, careful consideration must be given to the **reliability indicators** (catch trials). The following three indicators appear on the printed report and on the LCD Display for the threshold test. They are an important measure of patient reliability in taking the test (and of the reliability of the results). They are indicated as a ratio of the number responded to the number presented. For example, **1/3** indicates that the patient responded to **1** of the **3** catch trials presented.

FIXATION ERRORS - The ratio of the number of times the patient responded to a target placed in the blind spot versus the total number of times fixation was tested (i.e., total number of targets placed in the blind spot). Six **FIXATION catch trials** will be randomly presented for each eye in the C-20 TEST and N-30 TEST. Fixation errors indicate the patient is not maintaining good fixation during the test, is misaligned, or does not understand the test.

FALSE POSITIVE ERRORS - The ratio of the number of times the patient responded to a "pause" in the testing sequence (i.e., with no target presented) versus the total number of "pauses" in the testing sequence. Six **FALSE POSITIVE catch trials** will be randomly presented for each eye in the C-20 TEST, eight in the N-30 TEST. False positive errors indicate the patient is pressing the Button even if patient does not see any patterns or the patient does not understand the test.

FALSE NEGATIVE ERRORS - The ratio of the number of times the patient did not respond to a test pattern at the maximum possible contrast level of the instrument versus the total number of times that maximum possible contrast level patterns were tested. Three **FALSE NEGATIVE catch trials** will be randomly presented for each eye in the C-20 TEST, five in the N-30 TEST. False negative errors indicate the patient is likely to not be paying attention, does not understand the test, or has a severe loss at the location of the FALSE NEGATIVE catch trial(s).

For the threshold tests, the device utilizes a staircase threshold strategy known as a **Modified Binary Search (MOBS)**¹. The range of possible threshold level values for the **raw data** (patient threshold scores) is between **0 dB Maximum Contrast** (lowest patient sensitivity) and **56 dB Minimum Contrast** (highest patient sensitivity). The formula used to calculate the dB values is $\log_{10}(2048/c) * 10 * H$ where c ranges from 1 (minimum contrast) to 2048 (maximum contrast) and H is approximately 2. Note that **XX dB** will be displayed, if the threshold cannot be determined due to inconsistent patient responses which do not meet the **MOBS** threshold criteria. The magnitude of the threshold level values is directly correlated to the Humphrey Field Analyzer values.

The device also provides **MD & PSD** global statistical indices calculated from points over the entire visual field for the threshold test. These indices reduce the individual threshold scores to a single number to provide overall information about the entire visual field. The magnitude of the **MD & PSD** values are directly correlated to the Humphrey Field Analyzer **MD & PSD** indices. The actual formulas used for the MD & PSD indices calculations can be found in the references (2, 3).

"The **MD (Mean Deviation)** index signifies overall severity of field loss. It is affected both by the degree of loss and the number of affected locations. A positive number indicates that the average sensitivity is above the average normal for age, whereas a negative number indicates that the average sensitivity is below the average normal value." ²

When the **MD** value is **LESS** than that of **95%** of normal FDT fields, the percentile probability is given (P < 5%, P < 2%, P < 1%, or P < 0.5%) on the Operator LCD Display and on the printed report.

"The **PSD (Pattern Standard Deviation)** index is the standard deviation of the difference of each sensitivity value from an expected value (based on the normal value at that location and the mean deviation index), each difference weighted according to the variance of the normal values at that point. The **PSD** is small in a normal field, or in a field where all points are equally abnormal. The **PSD** becomes large as some points are more affected than others, and thus the **PSD** is an index of localized change in the field." ³

When the **PSD** value is **GREATER** than that of **95%** of normal FDT fields, the percentile probability is given (P < 5%, P < 2%, P < 1%, or P < 0.5%) on the Operator LCD Display and on the printed report.

-
- 1 Tyrrell RA, Owens DA: A New Technique to Rapidly Assess the Resting States of the Eyes and Other Threshold Phenomena: the Modified Binary Search (MOBS) Whitley Psychology Laboratories, Pennsylvania State University.
 - 2 Anderson, DR: Automated Static Perimetry Mosby Year Book, St. Louis, 1992; p. 84.
 - 3 Anderson, DR: Automated Static Perimetry Mosby Year Book, St. Louis, 1992; p. 86.

**SCREENING C-20 TEST
RESULTS SAMPLE**

OPERATING PROCEDURES

SCREENING C-20

NAME _____
 AGE 67 ID _____
 30 JUN 1997 03:02 pm

RIGHT EYE
 Test duration : 00:43 min
 Deviation

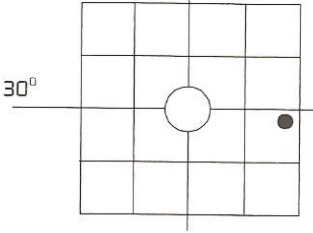



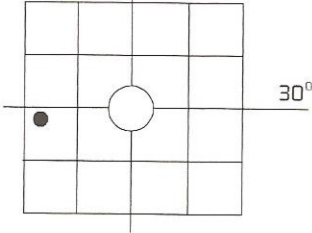

FIXATION ERRS 0/3
 FALSE POS ERRS 0/3

LEFT EYE
 Test duration : 00:40 min
 Deviation



FIXATION ERRS 0/3
 FALSE POS ERRS 0/3

	WITHIN NORMAL LIMITS
	MILD RELATIVE LOSS
	MODERATE RELATIVE LOSS
	SEVERE LOSS

WelchAllyn
 FREQUENCY DOUBLING
 TECHNOLOGY

 **Humphrey**
 SYSTEMS

**THRESHOLD C-20
TEST RESULTS
SAMPLE**

FULL THRESHOLD C-20

NAME _____
AGE 55 ID _____
01 JUL 1997 12:13 am

RIGHT EYE
Test duration : 03:28 min

Threshold (dB)

34	35	31	31
32	35	31	30
31	35	35	30
30	31	31	34

Deviation

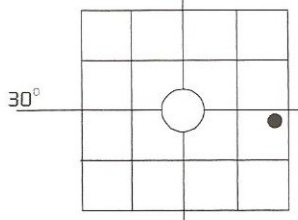

MD +2.54 dB
PSD +2.75 dB

FIXATION ERRS 0/6
FALSE POS ERRS 0/6
FALSE NEG ERRS 0/3

LEFT EYE

Test duration : 04:13 min

Threshold (dB)

34	30	33	31
31	30	31	33
30	33	31	29
32	29	28	28

Deviation

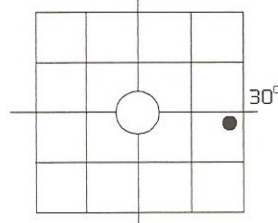

MD +0.88 dB
PSD +2.97 dB

FIXATION ERRS 0/6
FALSE POS ERRS 0/6
FALSE NEG ERRS 0/3

Probability Symbols

- P >= 5%
- P < 5%
- P < 2%
- P < 1%
- P < 0.5%

WelchAllyn
FREQUENCY DOUBLING
TECHNOLOGY

Humphrey
SYSTEMS

OPERATING PROCEDURES

THRESHOLD N-30 TEST RESULTS SAMPLE

FULL THRESHOLD N-30

NAME _____
 AGE 79 ID _____
 30 JUN 1997 06:45 am

RIGHT EYE
 Test duration : 04:07 min

Threshold (dB)

36	41	36	35	
30	41	37	40	35
-----37-----				
31	45	40	40	36
36	40	40	36	

Deviation

MD +6.10 dB
 PSD +4.36 dB

FIXATION ERRS 0/6
 FALSE POS ERRS 0/8
 FALSE NEG ERRS 0/5

LEFT EYE
 Test duration : 04:40 min

Threshold (dB)

38	28	40	36	
32	36	40	40	32
-----34-----				
36	34	33	34	34
36	33	32	36	

Deviation

MD +4.07 dB
 PSD +4.01 dB

FIXATION ERRS 0/6
 FALSE POS ERRS 0/8
 FALSE NEG ERRS 0/5

Probability Symbols

	P >= 5%
	P < 5%
	P < 2%
	P < 1%
	P < 0.5%

WelchAllyn
 FREQUENCY DOUBLING TECHNOLOGY

CALIBRATION AND SET-UP, MAINTENANCE AND TROUBLESHOOTING

CALIBRATION AND SET-UP

The **UTILITIES MENU** on the **FDT MAIN MENU** should not be needed unless calibration or a change of the instrument set-up defaults is needed (set-ups are set to defaults and date and time (EST) have been pre-set).

Set Date and Time

To set the date and time, select **UTILITIES MENU (BOTTOM Operator Button)** from the **FDT MAIN MENU** then select **SET-UP INSTRUMENT MENU (TOP Operator Button)** in the **UTILITIES MENU** and select **SET CLOCK MENU (TOP Operator Button)** in the **SET-UP INSTRUMENT MENU**.

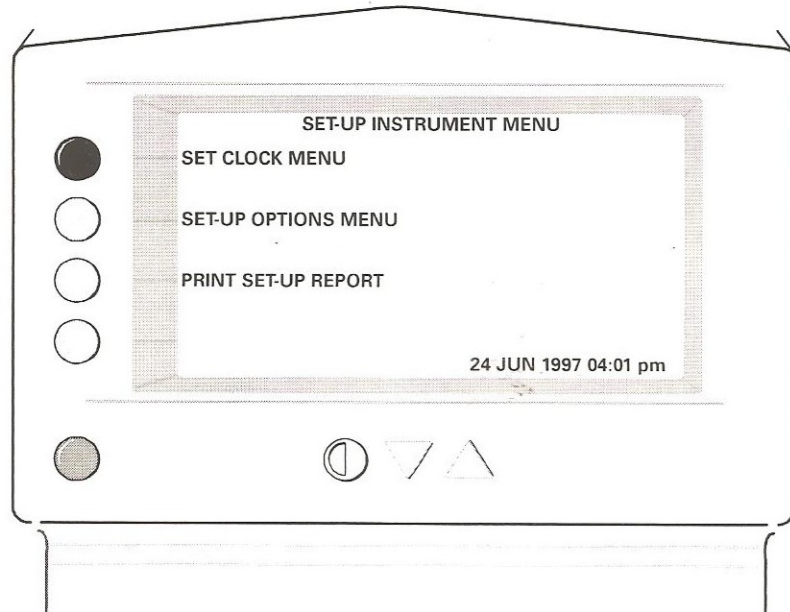
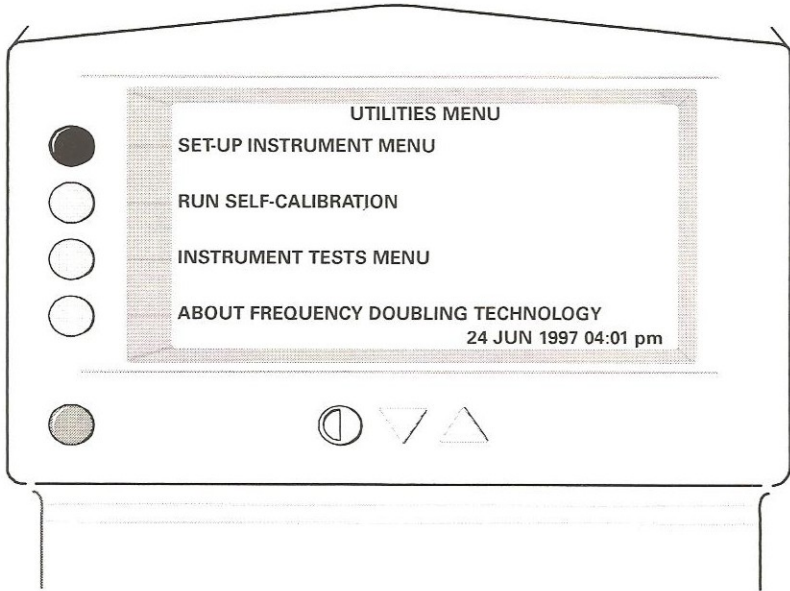
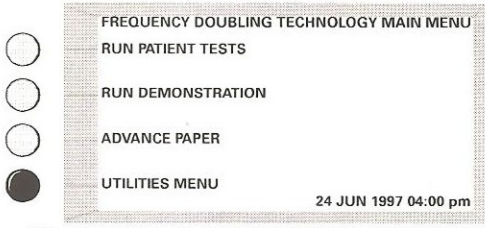

CALIBRATION AND SET-UP,
MAINTENANCE AND
TROUBLESHOOTING

Set-up Instrument Options

Select **NEXT CHOICE (3rd Operator Button from the top)** to select the clock setting you want to change. (**▲ INCREASE (TOP Operator Button)** and (**▼ DECREASE (2nd Operator Button from the top)** to change the setting. Select **ACCEPT SETTINGS (BOTTOM Operator Button)** when the **correct CLOCK** settings are displayed. Press the **GREEN Button** twice to return to the **FDT MAIN MENU**.

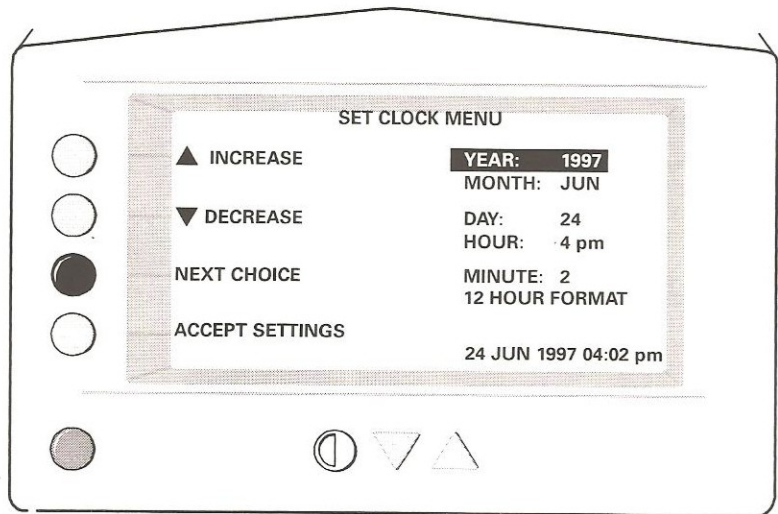

To **SELECT LANGUAGE** or **OPTIONS**, select **SET-UP OPTIONS MENU (2nd Operator Button from the top)**. Select **SELECT LANGUAGE (top Operator Button)** from the **SET-UP OPTIONS MENU** to choose the desired language for the Operator LCD Display and results printout. Use **NEXT CHOICE (3rd Operator Button from the top)** to select the desired language from the list.

Select **ACCEPT SETTINGS (Bottom Operator Button)** when the desired language choice is highlighted. Press the **GREEN Button** three times to return to the **FDT main menu**.

Select **OPTIONS (2nd Operator Button from the top)** from the **SET-UP OPTIONS MENU** to change instrument default settings.

Select **NEXT CHOICE (3rd Operator Button from the top)** to select the setting to change. Select **TOGGLE ON/OFF (Top Operator Button)** to change the highlighted setting. The settings include: **MAKE CLICK SOUND AT EACH BUTTON PRESS** and **AUTO PRINT REPORT AFTER TEST**. Both are selected as defaults.

Select **ACCEPT SETTINGS (BOTTOM Operator Button)** when the desired options are set. Press the **GREEN Button** three times to return to the **FDT MAIN MENU**.

Select **RESET TO DEFAULTS (3rd Operator button from the top)** in the **SET-UP OPTIONS MENU** and **ACCEPT SETTINGS** in the **OPTIONS MENU** to restore the options to factory defaults. Press the **GREEN Button** three times to return to the **FDP MAIN MENU**.

Calibration

This instrument does not require scheduled calibration. The instrument calibration is checked each time the instrument is powered ON and at the start of each test to be sure the unit is properly calibrated. If the instrument detects the need for calibration, the Operator LCD Display will display a needs calibration warning. If not calibrated when the needs calibration warning is displayed, the unit will continue to operate normally until the unit reaches the calibration limits. Once the calibration limits are reached, the unit will not operate normally until a calibration is completed successfully. Calibration may be performed at any time, not only when requested by the instrument.

To calibrate the instrument, select **UTILITIES MENU (BOTTOM Operator Button)** from the **FDT MAIN MENU** and then **RUN SELF-CALIBRATION (2nd Operator Button from the top)** in the **UTILITIES MENU**. Follow the Operator LCD Display instructions to start the calibration. The calibration will take several minutes and requires no operator interaction during calibration. If the calibration cannot be completed successfully, repeat the **RUN SELF-CALIBRATION** sequence again (up to 3 times). If SELF-CALIBRATION cannot be completed after 3 attempts, record the information on Operator LCD Display and contact an authorized customer service representative for assistance.

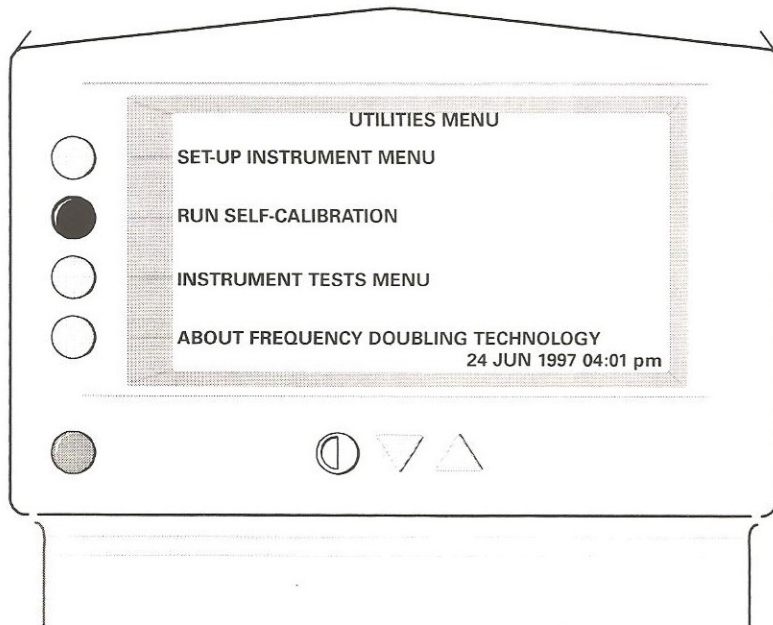

Note: Be sure to **cover the Patient Eyepiece** with the Calibration Cap shipped with each unit. If the Calibration Cap is not available, substitute something that will temporarily block light from entering the Patient Eyepiece or perform the calibration in a completely darkened room (black cloth over Patient Visor, etc.). The Operator LCD Display will indicate if there is too much ambient light to complete the calibration.

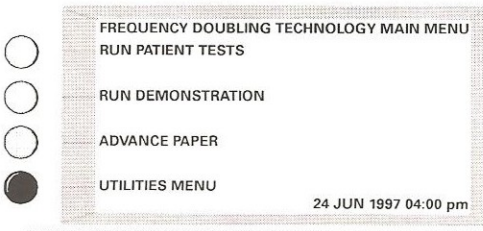

Software Upgrade

This instrument is designed with the ability to upgrade the operating software. For detailed software upgrade information, reference the software upgrade instructions available from authorized representatives.

The current software version is available in the **ABOUT FDT SCREEN** and on the bottom of the each **RESULTS PRINT-OUT**.

MAINTENANCE

This instrument requires no preventive inspection or maintenance. The only user maintenance required is replacing the printer paper and surface cleaning as necessary.

Printer Paper Replacement

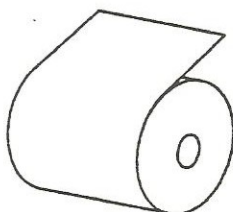

REF 11260

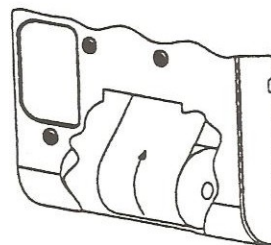

To load a new roll of paper, pull down the **Paper Access Door** (below the Operator LCD Display) using the Finger Tabs on the sides of the door (near the top). Remove the empty paper spool from the paper well.

Unwrap the paper from its bag, loosen the leading edge of the paper from the roll, and place the new roll of paper into the paper well with the **leading edge of the paper facing toward the outside** of the unit (toward you – see the diagram on the inside of the printer door).

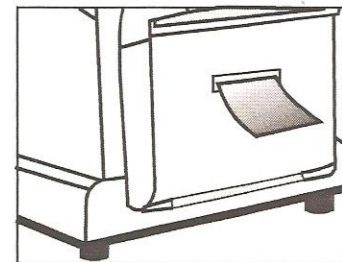
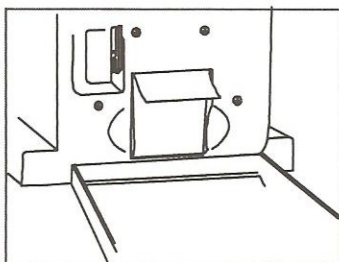
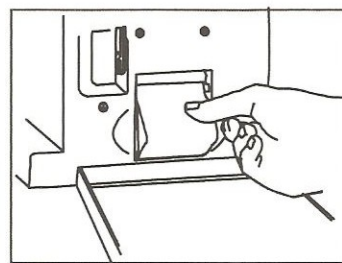
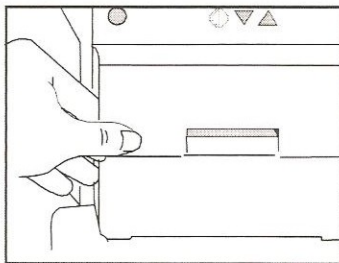

Place the leading edge of the paper onto the metal bar and push it into the unit under the roller bar. The instrument will automatically feed the paper through once you have inserted it far enough.

Close the Paper Access Door, being sure the paper is sticking out through the slot in the door. Tear off any excess paper if desired.

Note: The printer paper can be advanced by selecting **PAPER FEED (2nd Operator Button from the top)** in the results menu or by selecting **PAPER FEED (3rd Operator Button from the top)** in the **FDT MAIN MENU**.

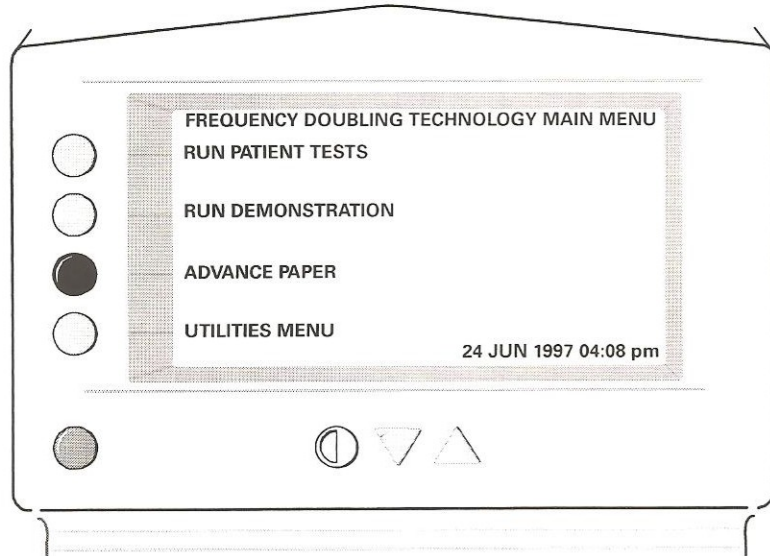

Note: Use only an appropriate heat-sensitive printer paper designed to be used with the Seiko Instruments 5000 series printer inside the instrument (reverse wound rolls only) or the print quality may be degraded, the printer life may be shortened, and the instrument warranty voided. Appropriate paper may be ordered through any authorized representative. Refer to the Replacement Parts and Accessories section of this manual for part number and ordering information.

Note: Because the printer paper is thermally activated, no printing will appear on the paper if it is inserted backwards.

Note: The printer paper is thermally activated, so it must be stored in a cool, dry, dark location to prevent exposure and degraded performance over time.

Note: Do not use transparent adhesive tape on printed portions of the printout, as those portions of the printout will then fade.

Note: Do not store the printed side of the printout in contact with plastic folders or sheets, as those portions of the printout will then fade.

Note: Do not allow any cleaning or disinfection solutions or other liquids to come into contact with the printer paper. Degraded print quality or printer damage may occur for new printouts and degraded printouts of previously printed results may occur (especially with Isopropyl alcohol).

FDT Replacement Parts and Accessories

DESCRIPTION	REF
FDT - Printer Paper (box of 5)	11260
FDT - Calibration Cap	112078-1
FDT - Computer Interface Cable	11228
FDT - Patient Response Button	11229
Fuse - Type T .315A 250V(115V, 2 required)	236706-3112
Fuse - Type T .160A 250V (230V, 2 required)	236706-3109
Power Cord - USA, Japan, Canada	76400
Power Cord - Europe	76402
Power Cord - United Kingdom	76404
Power Cord - Australia	76406
FDT - User's Guide - English	112098-1
FDT - User's Guide - French	112098FR-1
FDT - User's Guide - German	112098GR-1
FDT - User Guide - Italian	112098IT-1
FDT - User's Guide - Spanish	112098SP-1
FDT - Quick Reference Guide - English	112136
FDT - Quick Reference Guide - French	112136FR
FDT - Quick Reference Guide - German	112136GR
FDT - Quick Reference Guide - Italian	112136IT
FDT - Quick Reference Guide - Spanish	112136SP
FDT - Service Manual	112120

FDT Product Model Numbers (710 SERIES)

DESCRIPTION	REF
FDT - Domestic (115V)	00710-11
FDT - Canada (115)	00710-21
FDT - Europe (230V)	00710-31
FDT - France (230V)	00710-41
FDT - Germany (230V)	00710-51
FDT - Italy (230V)	00710-61
FDT - Spain (230V)	00710-71
FDT - United Kingdom (230V)	00710-81
FDT - Australia (230V)	00710-91

Cleaning, Disinfection and Sterilization

Cleaning

Clean the instrument as necessary by wiping the housing surfaces with a soft dry cloth or a soft cloth that has been **lightly** dampened with soapy water, 10% Clorox™/water solution, or 70% Isopropyl alcohol. Clean the Patient Eyepiece window and Operator LCD Display window with a soft, lint-free cloth **lightly** dampened with commercially available window cleaners (do not use soap) or 70% Isopropyl alcohol.

Disinfection

Patient contact surfaces (the Forehead Rest and Patient Response Button) may be disinfected as necessary by wiping the surfaces with a soft cloth that has been lightly dampened with 10% Clorox™/water solution or 70% Isopropyl alcohol. Be sure to allow the surface to dry thoroughly before patient contact.

Note: Do not allow cleaning or disinfection solutions or other liquids to seep into the seams in the housings or along the LCD display or into the user Buttons. Do not spray cleaning or disinfection solutions or other liquids directly onto the instrument. Damage to internal components may occur.

Note: Do not allow any cleaning or disinfection solutions or other liquids to come into contact with the printer paper. Degraded print quality or printer damage may occur for new printouts and degraded printouts of previously printed results may occur (especially with Isopropyl alcohol).

Sterilization



 **Do not sterilize the instrument or any of its components.**

TRUBLESHOOTING

The **INSTRUMENT TESTS MENU** (from the **UTILITIES MENU** provides the ability to test the instrument's inputs, outputs, serial port and A/D circuitry, if needed, for troubleshooting. Follow the menu choices to test the area of concern.

If the unit fails to power on (Operator LCD Display is off, no double beep), **confirm:**

- Approved power cord is connected to a power outlet and to The instrument Power Cord Inlet
- Power Switch is on **(I)**
- Operator LCD Display contrast is set to allow the display to be visible (use the triangular Up/Down Contrast Adjustment Buttons)
- Proper operating voltage selection
- Power outlet is live
- Fuses condition

Note: Refer to the Preparation for Use and Power On section of this manual for instructions to select the proper operating voltage or to inspect or change the fuses.

If the instrument does not print out the results, confirm the foam shipping wedge has been removed. Pull down the **Paper Access Door** below the Operator LCD Display) using the Finger Tabs on the sides (near the top) and **remove the foam shipping wedge** if not already removed. Close the printer door. Be sure the paper is sticking out through the slot in the door.

Failure to remove the shipping wedge will result in improper operation of the printer.

If the results printout is blank, confirm the paper is inserted correctly. Blank printouts will occur if the printer paper is inserted backwards. Also, confirm the correct type printer paper is being used. Improper paper type may cause blank or faint printouts. Refer to the Printer Paper Replacement section of this manual for instructions.

If you have an instrument problem that you cannot resolve, refer to the Service Information section of this manual for Technical Assistance information

WARRANTY INFORMATION

Zeiss Humphrey Systems warrants the Humphrey FDT Visual Field Instrument, when new, to be free from defects in materials and workmanship and to perform in accordance with manufacturer's specifications for a period of one year from the date of purchase from Zeiss Humphrey Systems or its authorized distributors or agents.

Zeiss Humphrey Systems will either repair or replace any components found defective or at variance from manufacturer's specifications within this time at no cost to the customer. It shall be the purchaser's responsibility to return the instrument directly to the regional authorized Service Center. This warranty does not include breakage or failure due to tampering, misuse, neglect, accidents, modifications or shipping. This warranty is also void if the instrument is not used in accordance with manufacturer's recommendations or if it is repaired by other than Zeiss Humphrey Systems or an authorized agent. Purchase date determines warranty. No other express warranty is given.

SERVICE INFORMATION

⚠ SERVICE or REPAIR to be PERFORMED by QUALIFIED, AUTHORIZED PERSONNEL ONLY. There are **NO USER SERVICEABLE PARTS INSIDE** the instrument.

Disassembly of the instrument beyond the extent required to change the PRINTER PAPER, FUSES, or PATIENT RESPONSE BUTTON as described in this manual presents a possible electrical shock hazard and will void the warranty.

All repairs on products under warranty must be performed or approved by an authorized service location. **Unauthorized repairs will void the warranty.** Products out of warranty should be repaired by an authorized service location or other qualified electronics personnel.

Technical Assistance Information

If you have an instrument problem that you cannot resolve, call the authorized service center listed below for assistance. Technical service support is available during normal business hours on normal business days at the authorized service location phone numbers listed below.

Zeiss Humphrey Systems

5160 Hacienda Drive
Dublin, California 94568
• 877-486-7473 • Fax: 925-557-4101

For customers outside of the USA, contact your nearest Humphrey/Zeiss authorized service location or distributor for assistance.

This instrument is manufactured exclusively for ZEISS HUMPHREY SYSTEMS by:
 Welch Allyn, Inc.
 4341 State Street Road
 Skaneateles Falls, New York 13153-0220 USA

INSTRUMENT SPECIFICATIONS

Dimensions: 25 cm [10"] wide x 48 cm [19"] deep x 43 cm [17"] high
Weight: less than 9 kg [20 lbs.]
Patient display size: 40° horizontal by 40° vertical square
Power requirements: 100-120 VAC/220-240 VAC, 50/60 Hz, 50 Watts maximum
Power Connection: IEC-320 standard power inlet connector for worldwide use
Power Cord: Approved hospital grade detachable power cord
Computer Interface: RS-232 Serial, 9-pin D male connector, null-modem cable
Printer: High-speed, high-resolution internal thermal printer

ENVIRONMENTAL SPECIFICATIONS

Operating Conditions

Operating Temperature: +15° C to +35° C [+59° F to +95° F]
 Operating Humidity: 10% to 90% non-condensing
 Operating Altitude: 500 hPa to 1060 hPa

Storage and Shipping Conditions

Storage Temperature: -20° C to +49° C [-4° F to +120° F]
 Storage Humidity: 0% to 95% non-condensing
 Storage Altitude: 500 hPa to 1060 hPa



TEST SPECIFICATIONS

Screening Test Strategy:

- Supra-threshold 20° (**SCREENING C-20**)
 - Contrast values: $p = 1\%$ (2 times), $p = 0.5\%$, maximum contrast

Threshold Test Strategies:

- Full Threshold 20° (**FULL THRESHOLD C-20**)
- Full Threshold Nasal 30° (**FULL THRESHOLD N-30**)
- MOBS computer automated staircase thresholding procedure
 - Initial Contrast: $p = 0.5\%$ contrast level
 - Staircase completion consists of at least four staircase reversals as well as upper and lower staircase boundaries within 0.3 \log_{10} units of each other.
 - MOBS threshold is calculated to be the mean of the last upper and last lower presentations satisfying the staircase completion criteria.

Reliability Indices:

- Fixation Monitoring: Heijl-Krakau fixation monitor
 - Catch trial contrast: 6 dB (~ 50%)
 - 3 catch trials in **SCREENING C-20 TEST**
 - 6 catch trials in **FULL THRESHOLD C-20** and **N-30 TESTS**
 - Presentation Order: Pseudo-Random
 - Pattern: 1° diameter circular FDT stimulus
- False Positive Catch Trials:
 - Catch trials contrast: 56 dB (~ 0%)
 - 3 catch trials in **SCREENING C-20 TEST**
 - 6 catch trials in **FULL THRESHOLD C-20 TEST**
 - 8 catch trials in **FULL THRESHOLD N-30 TEST**
 - Presentation Order: Pseudo-Random
- False Negative Catch Trials:
 - Catch trial contrast 0 dB (~ 100%)
 - 3 Catch trials in **FULL THRESHOLD C-20 TEST**
 - 5 Catch trials in **FULL THRESHOLD N-30 TEST**
 - Presentation Order: Pseudo-Random
 - Pattern: 1 of 17 FDT Patterns, Random

Stimulus:

- 17 FDT patterns plus OD and OS fixation catch trial patterns (4 patterns per visual field quadrant plus a central 5° radius pattern)
- Presentation Order: Random
- Spatial Frequency: 0.25 cycles/degree, cosinusoidal modulation
- Temporal Frequency: 25 Hz counter-phase flicker
- Duration: 200 to 400 ms
- Color: black and white
- Mean Background Illumination: 100 cd/m^2 nominal
- Contrast Range: 56 dB (~ 0%) to 0 dB (~ 100%) in \log_{10} steps
- Interstimulus Interval: 0 to 500 ms, Random

Screening Test Results:

- Deviation Plot with 4 qualitative loss classifications (Within Normal Limits, Mild Relative Loss, Moderate Relative Loss, Severe Loss) based on age-related normative references
- reliability Indices: Fixation and False Positive Catch Trials ratios

Threshold Test Results:

- Threshold (dB) Plot
- Deviation Plot with 5 probability level classifications ($P > = 5\%$, $P < 5\%$, $P < 2\%$, $P < 1\%$, $P < 0.5\%$) based on age-related normative references
- MD (Mean Deviation) and PSD (Pattern Standard Deviation) statistical Global Indices values with 5 probability level classifications ($P > = 5\%$, $P < 5\%$, $P < 2\%$, $P < 1\%$, $P < 0.5\%$) based on age-related normative references
- Reliability Indices: Fixation, False Positive, and False Negative Catch Trials ratios

STANDARDS COMPLIANCE

Product Safety

Class 1
IXPO- ordinary equipment
Continuous operation equipment



TYPE BF Indicates this is a Type B product with Type BF applied parts; the patient forehead rest and patient response Button.



ETL listed to comply with UL 2601-1 (1994) (USA)
ETL listed to comply with CSA C22.2 No. 601.1-M90 (Canada)
ETL listed to comply with IEC 601-1(1988 & 1990, including A1 & A2; Part 1)
CB certified to Medical Electrical Equipment EN60601-1
Amendment 2 by ETL



Electromagnetic Compatibility (EMC)

FCC Part 15, Class A (USA)

This device complies with CFR 47 Part 15 Class A of the FCC rules. Operation is subject to the following two conditions:

- (1) This device may not cause harmful interference, and
- (2) This device must accept any interference received, including interference that may cause undesired operation.

EN60601-1-2 (1993), IEC 601-1-2 (1993)

- EN55011 ISM Level B (Industrial/Scientific/Medical)
- EN61000-3-2 Harmonics
- EN61000-3-3 Fluctuations, Flicker
- EN61000-4-2 ESD, Criteria B
- EN61000-4-3 Radiated RF, Criteria A
- EN61000-4-4 EFT, Criteria B
- EN61000-4-5 Surge, Criteria B

Regulatory Approvals

FDA 510(k)



The CE mark on this device indicates it has been tested to and conforms with the provisions noted within the 93/42/EEC Medical Device Directive.

Authorized European Representative Address:

European Regulatory Manager
Carl Zeiss Jena GmbH
D-07740 Jena, Germany
Tel: 49-3641-642567 • Fax: 49-3641-642815

TECHNICAL
SPECIFICATIONS

FDT QUICK REFERENCE GUIDE

Start Patient Test

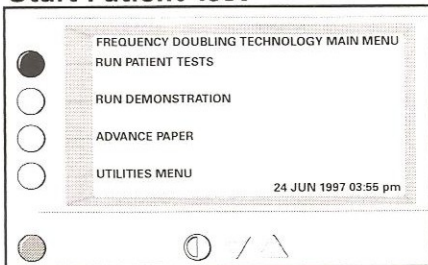

Enter Patient's Age

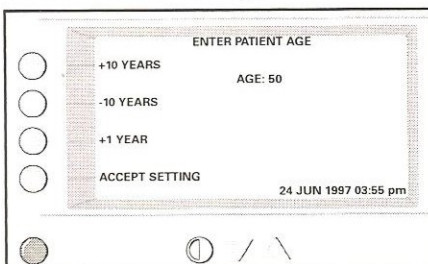

Video Screen Patterns

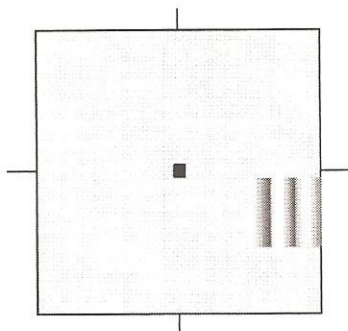

RUN RIGHT EYE TEST



RUN LEFT EYE TEST



- Select **RUN PATIENT TESTS** from the **FDT MAIN MENU**
- Enter the patient's **AGE** select **ACCEPT SETTING** when correct AGE is displayed
- Slide the **Patient Visor** to the **right eye test position** (this is to your right)
 - Note:** Slide the **Patient Visor** to the **left eye test position** now to **skip** the **right eye** test
- Place the **Response Button** in the patient's hand and show them how to press it
- Ask the patient to place their forehead on the **Forehead Rest** and look into **Patient Eyepiece** at the **Video Screen**
- Adjust the **height** of the chair or table (or both) to obtain a comfortable position for the patient
- **Explain the Test Procedure to the Patient**

"A demonstration of the test is running now. Can you see the black dot in the center and the entire lit video screen? You need to stare at the black dot in the center of the screen during the entire test."

"From time to time, you will see patterns of **flickering black and white vertical bars** that will briefly appear in different areas of the screen. The patterns will **sometimes** be **very faint** and at other times be **very distinct**. You are not expected to see the bar patterns at all times. Each time you see the **flickering black and white vertical bars** of one of the patterns, **press the response button once**. Can you see these patterns in the demonstration running now? You may practice now by pressing the button to respond to the patterns."

It is OK to blink and a good time to blink is when you press the response button. If you need to rest or ask questions during the test, you can pause the test at any time by pressing and holding down the response button. Do you have any questions? Do you understand how to take the test?"

"I will now start the test. There will be a few brief flashes and then the test will begin. Press the response button once each time you see the **flickering black and white vertical bars** of one of the patterns, even if the bars are very faint. Please remember to **stare at the black dot in the center of the screen** during the entire test."
- Select either **RUN SCREENING C-20 TEST**, **RUN FULL THRESHOLD C-20 TEST** or **RUN FULLTHRESHOLD N-30 TEST** from the **RIGHT EYE TEST MENU**.
 - Note:** Select **SKIP RIGHT EYE** *before* selecting a test to **skip** the **right eye** test.
 - Note:** You can press the **GREEN Button** to **Pause** or **Cancel** the test at any time or to return to the **FDT MAIN MENU**
- Slide the **Patient Visor** to the **left eye test position** at the end of the right eye test
- Select **RUN SCREENING C-20 TEST**, **RUN FULL THRESHOLD C-20 TEST** or **RUN FULL THRESHOLD N-30 TEST** from the **LEFT EYE TEST MENU**.
 - Note:** Select **SKIP LEFT EYE**, before selecting a test, to **skip** the **left eye** test and proceed to the **results menu**.
- Select **VIEW RIGHT** or **LEFT EYE RESULTS** to see the individual eye results on the **Operator LCD Display**

**PATIENT'S VIDEO
SCREEN PATTERNS**

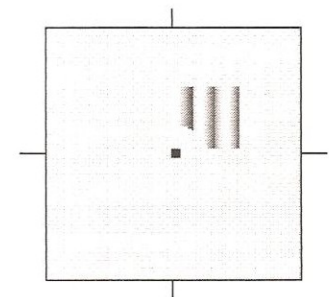
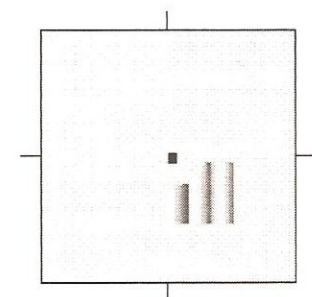
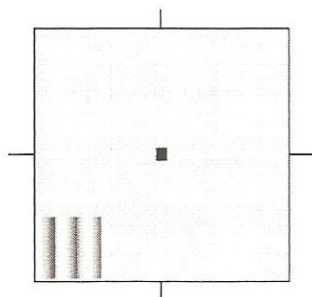
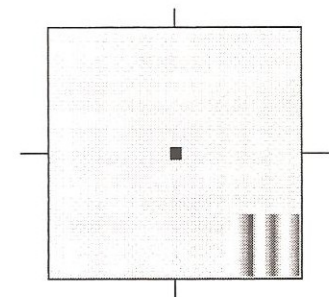
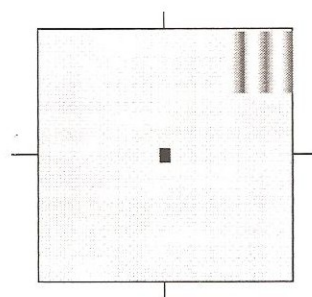
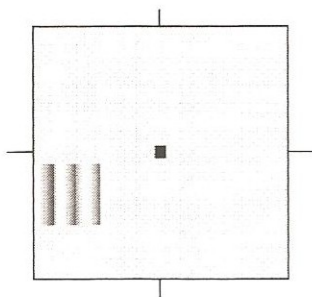
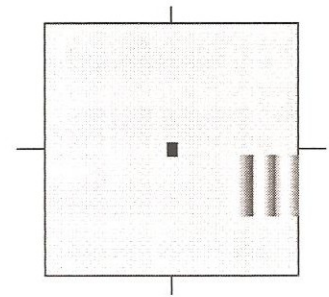
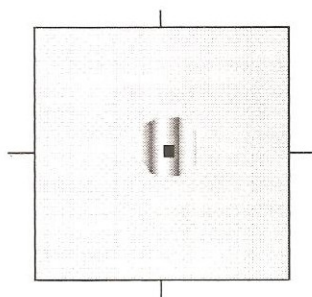
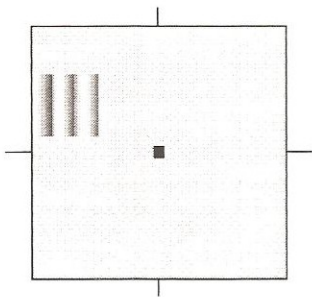
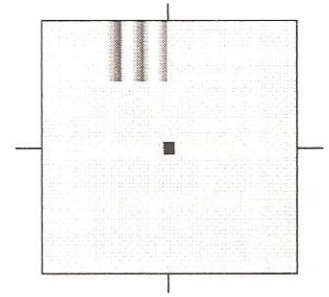
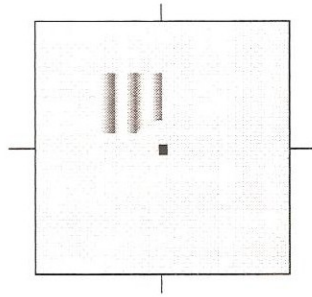
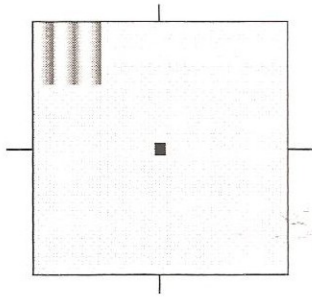

MEMO TO: Humphrey FDT Customers
FROM: Rick Farchione, Humphrey FDT Product Manager
SUBJECT: Humphrey FDT User's Guide Supplement for V3.00 Software

Dear Customer:

Your new Humphrey FDT Visual Field Instrument is being shipped with the latest software version already installed. This supplement serves to inform you of the functional changes that are not yet covered in the User's Guide included with your instrument.

List of Functional Changes Included in FDT Software version 3.00

- New screening test program and screening level options. There are now 2 screening test programs, whereas the User's Guide refers only to 1 screening test (formerly the Screening C-20 test). The new N-30 Screening program adds two additional test locations presented above and below the horizontal midline between 20 and 30 degrees eccentricity in the nasal visual field, like with the N-30 Threshold test. Also, there are now 2 screening level options for each screening program, the -5 (default) and -1. The Screening C-20-5 and N-30-5 programs utilize the P=5% significance limit as the baseline normal contrast level, whereas the Screening C-20-1 (formerly the Screening C-20) and N-30-1 programs utilize the P=1% significance limit as the baseline normal contrast level. See the clinical example in this supplement and refer to the Primer for Frequency Doubling Technology for a further explanation of the -5 and -1 screening level options.

Note: To change the default screening level found in the SCREENING TEST MENU from the C-20-5 & N-30-5 (5% level) programs to the C-20-1 & N-30-1 (1% level) programs, follow these keystrokes:

==> UTILITIES MENU
==> SET-UP INSTRUMENT MENU
==> SET-UP OPTIONS MENU
==> SET DEFAULT SCREENING LEVEL
use NEXT CHOICE and ACCEPT SETTINGS to select
==> SCREENING - 1% option listed

- Patient reliability (Fixation, False Positive, and False Negative) errors that exceed 1 are now highlighted on the operator LCD and marked with an asterisk (*) on the results printout.
- False Negative and False Positive catch trial presentations are now indicated by the symbols (+) & (-) on the operator LCD so they can be distinguished from regular test stimulus presentations.
- Pattern Deviation plots are now displayed and printed with Threshold test results. Refer to the Primer for Frequency Doubling Technology for information on Pattern Deviation plots.
- Faster Test Times. Optimized FDT test parameters to reduce test times by as much as 30%.

NOTE: If you use the FDT ViewFinder database application for Windows, you will need to upgrade to ViewFinder V2.00 or higher to support FDT V3.00 software.

New Screening N-30-5 Clinical Example

Because the FDT Screening N-30-1 (or C-20-1) and N-30-5 (or C-20-5) programs utilize different baseline normal contrast levels, they also differ in how they flag (shade) test locations as being outside normal limits. With the N-30-1 (or C-20-1) test, points are initially flagged when they reach the $P < 1\%$ probability significance level (i.e. the sensitivity level which is found less than 1% of the time in the normal population). With the N-30-5 (or C-20-5) test, points are initially flagged when they reach the $P < 5\%$ probability significance level (i.e. the sensitivity level which is found less than 5% of the time in the normal population), and thus there is a greater chance that any point may be deemed outside normal limits. Therefore, the N-30-5 (or C-20-5) test is slightly more sensitive, readily identifying more extensive loss. Below is a clinical example that demonstrates this difference with a comparison between the Screening N-30-1 and N-30-5 programs.

Screening N-30-1

NAME: _____

AGE: 64 **ID:** _____

04 MAR 2001 2:35 pm

RIGHT EYE



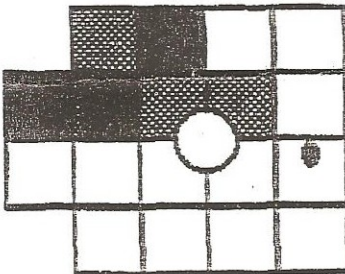

Test Duration: 01 : 12 min

Deviation



Fixation Errs: 0/3
False Pos Errs: 0/3

Probability Symbols

	P \geq 1%
	P < 1%
	P < 0.5%
	NOT SEEN AT MAXIMUM

Screening N-30-5

NAME: _____

AGE: 64 **ID:** _____

04 Mar 2001 02:40 pm

RIGHT EYE



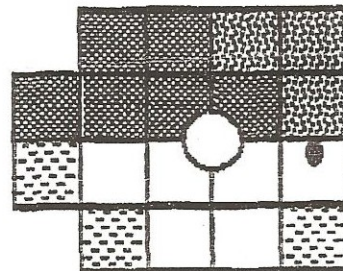

Test Duration: 01 : 42 min

Deviation



Fixation Errs: 0/3
False Pos Errs: 0/3

Probability Symbols

	P \geq 5%
	P < 5%
	P < 2%
	P < 1%

If you have any questions or problems, please contact:
Humphrey Systems Customer Service
Phone (toll free): 1 - 877 - 486 - 7473 (then press 3)